

OPERATION MANUAL

MODEL 506A

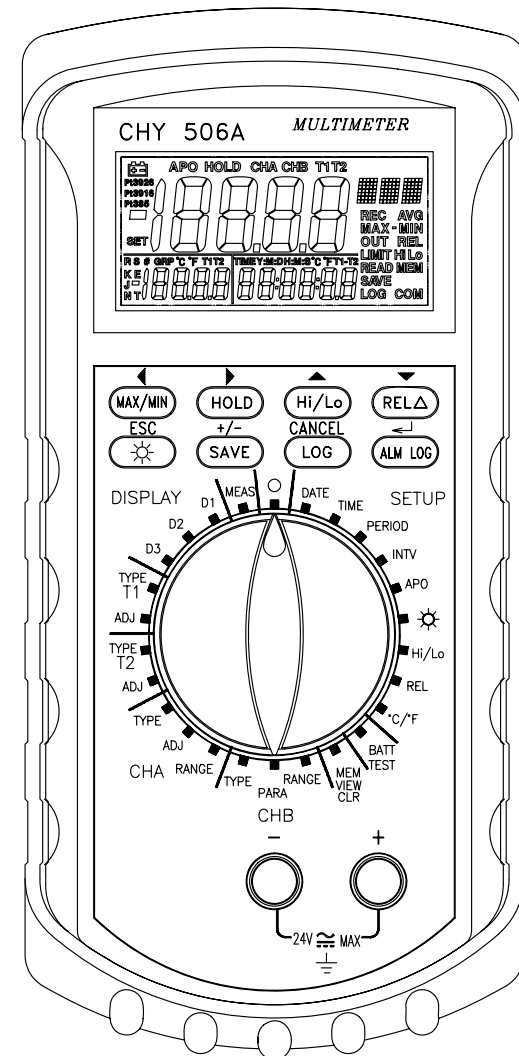

CE

B. Status Sets (from Instrument to Remote)

B.1 Condition:

Case: PC queries the all of logger counters from meter.

Ex. PC send "\$001G/r", then meter response "!001G005150000200000/r"

Means:

Here meter ID: 001,

Save counter: 515

Log Group counter: 2

ALM logger counter: 0

/r → <CR><LF> (Hex,0D,0A).

B.2 Condition:

Case: PC queries the LOG data in GROUP 6th of meter ID 001.

Ex. PC send "#001L00006/r", then meter response

">001L0000111554170704111220420900115000001/r"

PC sends "#001D00006/r", then meter will dump all of data of group 6th.

"> 001D00006/rxxxxxx/rxxxxxx/rxxxxxx/r....."

Means:

>001L : meter response , Here meter ID: 001

Scale: degree C

Logging Mode: 1 (logging T1 input)

T1_type: K type

T2_type: K type

Decimal Point: 1

ChA_type: ohm

ChB_type: User define, %RH

Time: year: 2004; month: 11; day: 12; hour: 20; minute: 42; second:09

Logger counts: 115

Interval: 1 second

xxxxxx : Value

/r → <CR><LF> (Hex,0D,0A).

Alarm Log Data(AD) mode=1,mode=2	7+ 30*n	S	GroupID (/r) c/f mode T1_type T2_type <u>AC</u> Time Value 5+2 1 1 1 1 5 12 6 H/L ST/SP 1 2	√
Alarm Log Data(AD) mode=3	7+ 32*n	S	GroupID (/r) c/f mode dp cha_type <u>AC</u> Time Value 5+2 1 1 1 1 5 12 6 H/L ST/SP /r 1 2 2	√
Alarm Log Data(AD) mode=4	7+ 39*n	S	GroupID (/r) c/f mode dp chb_type chb_text <u>AC</u> Time 5+2 1 1 1 2 6 5 12 Value H/L ST/SP /r 6 1 2 2	√
Battery Voltage(VB)	6	S	00 . 00 V 2 1 2 1	√

Note:

1. Communication Protocol : 9600 , 8, E, 2.

2. /r → <CR><LF> (Hex,0D,0A).

TABLE OF CONTENTS

PAGE

1. Safety Notice	1
2. Specifications	2
2.1 Electronic Specifications.....	2
2.2 Accuracy.....	2
3. Names of Outer Parts	3
4. Battery Installation	6
5. Turn On and Off Model 506A	7
6. Check Battery Voltage	7
7. Measurement and Main Function of Buttons	7
7.1 MIN/MAX Button.....	8
7.2 HOLD Button.....	8
7.3 Hi/Lo Button.....	8
7.4 RELA Button.....	8
7.5 ☼ Button.....	8
7.6 LOG Button.....	8
7.7 SAVE Button.....	9
7.8 ALM LOG Button.....	9
8. Measurement and Main Function of Buttons	9
8.1 D1-Setting the Main Display.....	9
8.2 D2-Setting Second Display.....	10
8.3 D3-Setting Third Display.....	10
8.4 T1 TYPE and T2 TYPE-Setting the Types of Thermocouple for T1 or T2.....	10
8.5 T1 ADJ and T2 ADJ-Setting the Off-Set Adjustment for T1 or T2.....	10
8.6 CHA TYPE-Setting the Types of RTD for CHA.....	11
8.7 CHA ADJ-Setting the Off-Set Adjustment for RTD.....	11
8.8 CHA RNGE-Setting the Resolution for Channel A (CHA).....	11
8.9 CHB TYPE-Setting the Unit for Channel B.....	12
8.10 CHB PARA-Create Special Unit for Channel B (CHB).....	12
8.11 CHB RNGE-Select the Resolution for Channel B (CHB).....	12
8.12 MEN VIEW CLR-Setting.....	12
8.13 °C/°F Selecting Temperature Unit (°C/°F).....	15
8.14 REL-Setting Reference Value for Relative Reading.....	15
8.15 Hi/Lo-Setting High and Low Limits for Alarm and Alarm Log.....	16
8.16 ☼-Setting Time Length of Backlight.....	16

8.17 APO-Auto Power Off Time Setting.....	16
8.18 INVT-Set Time interval of data logging.....	16
8.19 PERIOD-Set length of Time of data logging.....	17
8.20 TIME-Time Setting.....	17
8.21 DATE-Date Setting.....	17
9. Maintenance.....	18

2. Data Format Definition

Name	Len Byte	Type	Description	Rd	Wr
ID Number (ID)	3	S	1 ~ 999 (ASCII)	✓	✓
Description (DE)	40	S		✓	✓
Time (TI)	12	S	YYMMDDHHMMSS	✓	✓
Time_INV set	19	S	GroupID hour minute second /r 5 4 4 4 2	✓	✓
DATA OUT (#IDN)	47	S	GroupID T1_data T1_type T2_data T2_type c/f cha_data 5 6 1 6 1 1 7 chat_type chb_data chb_type chb_text cha/chb /r 1 7 2 6 2 2	✓	
Saved Data Counter (SC)	5	S	Counts 5	✓	
Log Data Counter (LC)	5	S	Counts 5	✓	
Alarm Counter (AC)	5	S	Counts 5	✓	
Saved Data (SD) mode=1,mode=2	34	S	GroupID SC c/f mode T1_type T2_type Time Value /r 5 5 1 1 1 1 12 6 2	✓	
Saved Data (SD) mode=3	34	S	GroupID SC c/f dp cha_type Time Value /r 5 5 1 1 1 2 6 2	✓	
Saved Data (SD) mode=4	41	S	GroupID SC c/f dp chb_type chb_text Time Value /r 5 5 1 1 2 6 12 6 2	✓	
Log Status (LS)	43	S	GroupID c/f mode T1_type T2_type dp cha_type 5 1 1 1 1 1 1 chb_type chb_text <u>TI</u> <u>LC</u> <u>TSEC</u> /r 2 6 12 5 6 2	✓	
Log Data (LD) n = recorded channel x LC	7+ 8*n	S	GroupID(/r) D1 /r D2 /r ... Dn /r 5+2 6 2 6 2 ... 6 2	✓	
Sampling Time (TSEC)	6	S	HHMMSS		
Alarm Limit Counts (LMS)	12	S	Hi-Limit Lo-limit 6 6		✓

A4. Quick Reference



1. 506A-Program

Mode:	Channel:	Record mode
MODE=1	Record T1	SAVE,ALARM and Logger
MODE=2	Record T2	SAVE,ALARM and Logger
MODE=3	Record CHA	SAVE,ALARM and Logger
MODE=4	Record CHB	SAVE,ALARM and Logger
MODE=5	Record T1 and T2	Logger
MODE=6	Record T1, T2 and CHA	Logger
MODE=7	Record T1, T2 and CHB	Logger

1. Safety Notice

The following safety information must be observed to ensure maximum personal safety during the operation at this meter:

- This instrument contains no operator serviceable part. Service should be done by qualified person only.
- Do not use the meter if the meter or test leads look damaged, or if you suspect that the meter is not operating properly.
- Before open the case of the meter, be sure to remove all the accessories including thermocouples connected to the meter.
- When the low battery indicator (🔋) shown in the display, please change the battery immediately.
- Do not use this meter in the dangerous circumstances (such as: explosive gas, vapor).
- Please use this meter according to instruction, or it may cause damage of the protective function of the meter.

	AC Alternating Current		Ground
	DC Direct Current		

2. Specifications

Display: 4 1/2 digit liquid crystal display (LCD) with a maximum reading of 19999.

Low Battery Indication: The “” displayed and blinking when the battery voltage drops below the operating level.

Measurement Rate: 2.5 times per second (nominal).

Continuous Record:

1. Single channel recording: 32000 records (T1 or T2 or CHA or CHB).
2. Multi channel recording: 6500 records (T1+T2 or T1+T2+CHA or T1+T2+CHB).

ALM Record: 5400 samples with start/stop time. (Max.)

Single Record: 6500 samples with real-time data. (Max.)

Operating Environment: 0°C to 50°C at < 70% R.H.

Storage Temperature: -20°C to 60°C, 0 to 80% R.H. with battery removed from meter.

Safety: CE

Power: single standard 9-volt battery (NEDA 1604, JIS 006P, IEC 6F22).

Battery Life: 100 hours typical with carbon-zinc.

Dimensions: 192mm (H) x 91mm (W) x 52.5mm (D).

Weight: 435g including battery.

Accessories:

- K-type thermocouples (2 pcs)
- Co-axial cable (RTD) (1pcs)
- RS232 transmission cable (1pcs)
- CD-ROM (software) (1pcs)
- 9V battery (installed) (1pcs)
- Operating manual

2.1 Electronic Specifications:

Thermocouple(T1、T2)Measuring Range:

K-TYPE (Resolution 0.1°): -200°C to 1372°C, -328°F to 2501°F

J-TYPE (Resolution 0.1°): -210°C to 1200°C, -346°F to 2192°F

T-TYPE (Resolution 0.1°): -200°C to 400°C, -328°F to 752°F

E-TYPE (Resolution 0.1°): -210°C to 1000°C, -346°F to 1832°F

R-TYPE (Resolution 1°): 0°C to 1767°C, 32°F to 3212°F

S-TYPE (Resolution 1°): 0°C to 1767°C, 32°F to 3212°F

N-TYPE (Resolution 0.1°): -50°C to 1300°C, -58°F to 2372°F

Resolution: 0.1°C /1°C, 0.1°F /1°F (Auto Ranging)

2.2 Accuracy:

K/J/T/E TYPE

±(0.05% rdg + 0.3°C) on -50°C to 1370°C

±(0.05% rdg + 0.7°C) on -50°C to -210°C

±(0.05% rdg + 0.6°F) on -58°F to 2501°F

±(0.05% rdg + 1.4°F) on -58°F to -346°F

N -TYPE

±(0.05% rdg + 0.8°C) on -50°C to 0°C

±(0.05% rdg + 0.4°C) on 0°C to 1300°C

±(0.05% rdg + 1.6°F) on -58°F to 32°F

±(0.05% rdg + 0.8°F) on 32°F to 2372°F

A. Command Sets (from Remote to Instrument)

A.1 Instrument Setup (%), only use for broadcasting

Command Syntax	Command Name	Description
% <u>ID</u> <u>I</u> <u>ID</u>	New ID	<u>ID</u> : original ID <u>ID</u> : New ID
%000 <u>R</u>	Read ID	
% <u>ID</u> <u>D</u> <u>DE</u>	Setup description	<u>DE</u> : Descriptive Text
% <u>ID</u> <u>T</u> <u>TI</u>	Timer setup	<u>TI</u> : timer count
% <u>ID</u> <u>L</u> <u>LM</u>	Limit setting	<u>LM</u> : Hi/Lo limit and Range
% <u>ID</u> <u>S</u> <u>TSEC</u>	Log sampling time	<u>TSEC</u> : Log sampling time
% <u>ID</u> <u>M</u>	Clean Memory	

Unknown or Error Echo → ?

A.2 Instrument Status (\$)

Command Syntax	Command Name	Description
\$ <u>ID</u> <u>G</u>	Read group counter	Echo: ! <u>ID</u> <u>G</u> <u>SC</u> , <u>LC</u> , <u>AC</u> <u>SC</u> : saved group count <u>LC</u> : log group count <u>AC</u> : alarm count
\$ <u>ID</u> <u>D</u>	Read description	Echo: ! <u>ID</u> <u>D</u> <u>DE</u>
\$ <u>ID</u> <u>T</u>	Read Timer	Echo: ! <u>ID</u> <u>T</u> <u>TI</u>
\$ <u>ID</u> <u>L</u>	Read Limits Value	Echo: ! <u>ID</u> <u>L</u> <u>LMS</u>
\$ <u>ID</u> <u>S</u>	Read Sampling Time	Echo: ! <u>ID</u> <u>S</u> <u>TSEC</u>
\$ <u>ID</u> <u>B</u>	Read Battery Voltage	Echo: ! <u>ID</u> <u>B</u> <u>VB</u>

Unknown or Error Echo → ?

A.3 Measurement (#)

Command Syntax	Command Name	Description
# <u>ID</u> <u>N</u>	Read current data	Echo: > <u>ID</u> <u>N</u> # <u>IDN</u> # <u>IDN</u> : Current Data
# <u>ID</u> <u>S</u> [<u>SC</u>]	Read saved data	Echo: > <u>ID</u> <u>S</u> <u>SD</u> <u>SD</u> : Saved Data
# <u>ID</u> <u>L</u> [<u>LC</u>]	Read log status	Echo: > <u>ID</u> <u>L</u> <u>LS</u>
# <u>ID</u> <u>D</u> [<u>LC</u>]	Read log data	Echo: > <u>ID</u> <u>D</u> <u>LD</u>
# <u>ID</u> <u>G</u> [<u>Start</u>], [<u>Stop</u>] 5 1 5	Read saved data group	Echo: > <u>ID</u> <u>G</u> <u>SDG</u>
# <u>ID</u> <u>B</u>	Read alarm log data	Echo: > <u>ID</u> <u>B</u> <u>AD</u> <u>AD</u> : Alarm Log Data

Unknown or Error Echo → ?

8.20 TIME-Time Setting

To set or change the system time. Place rotary switch at position "TIME" mode. The time and date on the third display panel should blink. Enter from left to right in the following format HH:MM:SS. Press On (▲), under (▼) button printed on the overlay in white word to set the system date. Press the "ENTER" button to confirm. Exit this function by pressing ESC button.

Except these 2 positions mentioned above, all other position are for system setting, the indicator "SET" shows at left side of LCD when place the rotary switch at any of these system setting positions. And 2nd functions of buttons are active.

HH: Interval Hour (0~23)

MM: Interval Minute (0~59)

SS: Interval Second (0~59)

MAX: 23:59:59

MIN:00:00:01

8.21 DATE-Date Setting

To set or change the system data. Place rotary switch at position "Date" mode. The time and date on the third display panel should blink. Enter from left to right in the following format YY:MM:DD. Press On (▲), under (▼) button printed on the overlay in white word to set the system date. Press the "ENTER" button to confirm. Exit this function by pressing ESC button.

Except these 2 positions mentioned above, all other position are for system setting, the indicator "SET" shows at left side of LCD when place the rotary switch at any of these system setting positions. And 2nd functions of buttons are active.

Y: Interval year (20 "00" ~20 "99")

M: Interval month (1~12)

D: Interval date (1~31)

MAX: 99:12:31

MIN: 00:01:01

9. Maintenance

Periodically wipe the case with a damp cloth, detergent and do not use abrasives or solvents.

WARNING:
To avoid possible electrical shock, disconnect the thermocouple connectors from the thermometer before removing the cover.

R/S-TYPE

$\pm(0.05\% \text{ rdg} + 2^{\circ}\text{C})$ on 0°C to 1767°C

$\pm(0.05\% \text{ rdg} + 4^{\circ}\text{F})$ on 32°F to 3212°F

CHA (RTD) Measuring Range:

Acceptable RTD Type: Pt385(100Ohm) · Pt3916(100Ohm) · Pt3926(100Ohm).

Temperature: -200°C to 800°C , -328°F to 1472°F

Resolution: 0.01, 0.1 for above $\pm 200^{\circ}\text{C}/^{\circ}\text{F}$.

Accuracy: $\pm 0.05\% \text{ rdg} + 0.2^{\circ}\text{C}$ or $\pm 0.05\% \text{ rdg} + 0.4^{\circ}\text{F}$

Resistance: 0 Ohm to 199.99 Ohm, 200.0 Ohm to 400.0 Ohm.

Resolution: 0.01, 0.1 for above 200 Ohm.

Accuracy: $\pm 0.05\% \text{ rdg} + 0.1 \text{ Ohm}$.

CHB (ADAPTER) Measuring Range:

Accuracy: $\pm(0.1\% \text{ rdg} + 10\text{dpts})$ on 200mV

$\pm(0.5\% \text{ rdg} + 4^{\circ}\text{dpts})$ on 2000mV

Stated accuracy at $23^{\circ}\text{C} \pm 5^{\circ}\text{C}$, $<75\% \text{ R.H.}$

Temperature Coefficient: 0.1 times the applicable accuracy specification per $^{\circ}\text{C}$ from 0°C to 18°C and 28°C to 50°C (32°F to 64°F and 82°F to 122°F).

Input Protection: 24V DC or 24V AC rms maximum input voltage on any combination of input pins.

3. Names of Outer Parts:

Front Side:

1. LCD.
2. Push buttons.
3. Rotary switch.
4. Socket of CHB (channel B) for voltage input.

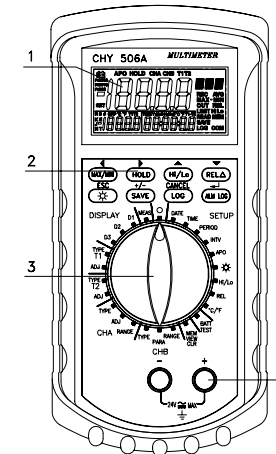

Top Side:

1. Socket of power (DC 12V, more then 100mA).
2. RS232 (Optical Interfaced) port.
3. Socket of CHA (channel A) for RTD input.
4. Sockets of K type thermocouples T1 and T2.

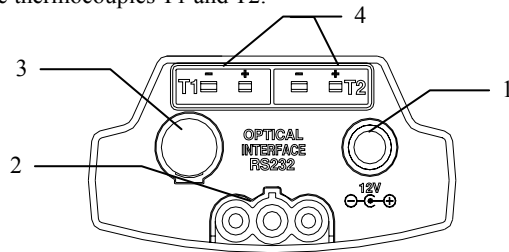

Connection Of RTD

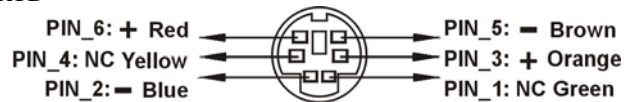

Configuration of Mini-Din Connector

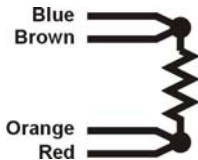

Wire connection to RTD

LCD:

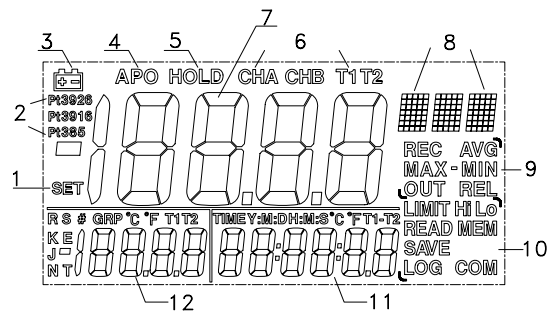

Number	Display	Function
1	SET	Setting mode
2	Pt385/3916/3926	Type of RTD at CHA (channel A)
3		Low battery
4	APO	Auto power off
5	HOLD	Hold measured reading

8.17 APO-Auto Power Off Time Setting

Use this function to change the time for the auto power off (APO) function. Place rotary switch at position “INVT”, and the indicator “APO” and the main display will blink on the LCD, and the previous setting will be displayed. The default time for APO is 1 minute. Press On (▲), under (▼) button printed on the overlay in white word to set the APO time. On (▲), under (▼) direction key: Time value, right (▶), “left (◀) direction key: Time figure. Press “CANCEL” button to back to previous setting. Confirm selection and exit setting mode by pressing “confirm (↵)” button. Press “ESC” button to abort change and exit the setting mode with previous setting remains unchanged. Confirm selection and exit setting mode by pressing “confirm (↵)” button.

MAX: 9998 minutes

MIN: 0001 minutes

Disable APO function: To set the time at 9999 will disable APO function.

APO Function will be Disabled also in Follow situation:

External power is used.

RS-232 function is used.

MAX, MIN, MAX-MIN, AVG function is used.

Data logger function is used.

8.18 INVT- Set Time interval of data logging

Place rotary switch at position “INVT” mode to set the time. The indicator “INV” will be blink on the top-right of the LCD and the pervious settings are displayed. Press On (▲), under (▼) button printed on the overlay in white word to change the time interval. Setting is from left to right of the following format (HH:MM:SS).

Pressing overlay “ENTER” button to confirm. To exit this function, press the ESC button.

Except these 2 positions mentioned above, all other position are for system setting, the indicator “SET” shows at left side of LCD when place the rotary switch at any of these system setting positions. And 2nd functions of buttons are active.

HH: Interval Hour (0~23)

MM: Interval Minute (0~59)

SS: Interval Second (0~59)

MAX: 23:59:59

MIN: 00:00:01

8.19 PERIOD- Set length of Time of data logging

Place the rotary switch at position “Period” to set the total length of time for data recording in the format of DD.HH.MM. At this position, indicator “PER” blinks at right upper corner of the LCD and the third display (the lower right display) shows the previous setting with the HH blinks. The blinking number can be changed with upward (▲) or downward (▼) direction buttons, and blinking position can be changed with right (▶) or left (◀) direction buttons.

8.13 °C/°F-Selecting Temperature Unit (°C/°F)

Place the rotary switch at position “°C/°F”, LCD shows the indicator “SET” at left side and a blinking °C or °F at upper-right corner. Press direction keys (▲) or (▼) to change between °C and °F. Press “ESC” key to end the set-up mode (indicator °C or °F ends blinking, and indicator “SET” disappears, but keep the previous setting unchanged. Press “CANCEL” key to return to previous setting but remain in setting mode. Press enter key (↵) to confirm the selection and end the setting mode.

8.14 REL-Setting Reference Value for Relative Reading

Place the rotary switch at position “REL”, LCD shows the indicator “SET” at left, and a blinking “REL” at upper-right corner. Main display shows previously set reference value with right most digit blinking. Change the value of blinking digit with (▲) and (▼) keys and change between “+” and “-“ with “+/-“ key. Change the blinking position with (◀) and (▶) key.

Press “ESC” key to end the set-up mode (indicator REL ends blinking, and indicator ”SET” disappears, the previous setting remains unchanged). Press “CANCEL” key to return to previous setting but remain in setting mode. Press enter key (↵) to confirm the setting and end the setting mode.

8.15 Hi/Lo-Setting High and Low Limits for Alarm and Alarm Log

Refer to 6.5 “Hi/Lo” button and 6.8 “ALM LOG” button for functions of “Hi/Lo alarm” and “alarm log”. Place the rotary switch at position “Hi/Lo”, LCD shows the indicator “SET” and “limit” at left and right, respectively, and a blinking “Hi” at upper-right corner. Main display shows previously set Hi-limit with right most digit blinking. Change the value of blinking digit with (▲) and (▼) keys and change between “+” and “-“ with “+/-“ key. Change the blinking position with (◀) and (▶) key.

Press “ESC” key to end the set-up mode (indicator °C or °F ends blinking, and indicator “SET” disappears, but keep the previous setting unchanged). Press “CANCEL” key to return to previous setting but remain in setting mode. Press enter key (↵) to confirm the setting, end the setting mode of Hi-limit and enter setting mode of Lo-limit with the indicator “Lo” blinking at upper-right corner.

Set the Lo-limit value same way as setting Hi-limit.

Based on measuring types to set the resolution, there is no decimal point when setting.

8.16 ☀-Setting Time Length of Backlight

Place the rotary switch at position “☀”, LCD shows the indicator “SET” at left. Main display shows previously set value with right most digit blinking. Change the value of blinking digit with (▲) and (▼) keys and change between “+” and “-“ with “+/-“ key. Change the blinking position with (◀) and (▶) key. Press “ESC” key to end the set-up mode (indicator REL ends blinking, and indicator “SET” disappears, the previous setting remains unchanged). Press “CANCEL” key to return to previous setting but remain in setting mode. Press enter key (↵) to confirm the setting and end the setting mode.

6	CHA/CHB/T1/T2	Channel of main display
7		Main display
8		Unit of main display
9	REC AVG MAX-MIN OUT REL	REC: Record MAX/MIN value AVG: Average value MAX-MIN: Maximum value and minimum value REL: Relative value
10	LIMIT/Hi Lo READ MEM SAVE LOG COM	Function indications
11		3 rd Display
12		2 nd Display

Buttons:

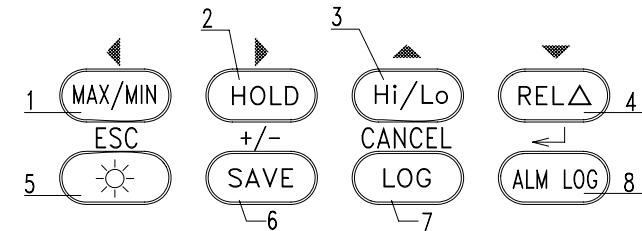

Number	Functions	Main Function	2nd Function
1	 MAX/MIN	MAX/MIN	Move to left
2	 HOLD	Data hold	Move to right
3	 Hi/Lo	Alarm when out of set limits	Move upward
4	 REL Δ	Display relative value	Move downward
5	ESC 	Backlight On/OFF	Exit
6	+/- SAVE	Single record	Change between positive and negative
7	CANCEL LOG	Continuous record	Abandon setup
8	 ALM LOG	Record the out of limit data and time	Enter

Rotary Switch:

1. Off position.
2. Work position.
3. Main/2nd/3rd display setup.
4. Sockets of K type thermocouples T1 and T2 setup.
5. RTD (CHA) setup.
6. ADAPTER (CHB) setup.
7. Data processing.
8. Battery test.
9. Setting.

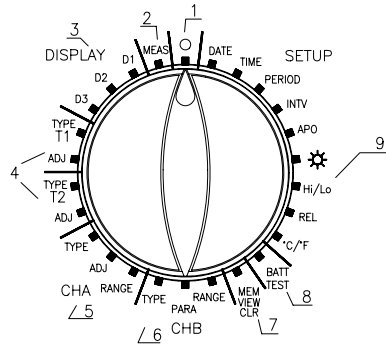

4. Battery Installation

Remove the two screws from the back of the meter and lift off the battery case.



Note:

It is need to replace the battery less than 20 sec. to avoid the time of system was reset.

Press direction keys ▲ or ▼ to change the indicator among “READ MEM SAVE”, “READ MEM LOG” and “READ MEM LIMIT”.

Press “←” key to enter the indicated set of recorded data.

In “READ MEM SAVE” and “READ MEM LIMIT”, press direction keys ▲ or ▼ to move among the data with the measurement reading shown in main display, sequence number in second display and time in third display.

There may be more than one group of data in “READ MEM LOG”, right after entering “READ MEM LOG” data, second show GRP 0001, press direction keys ▲ or ▼ to move among the different group of data, press “←” key to enter the group indicated in second display.

Press direction keys ▶ or ◀ to move to the data of different channels in the same record and press direction keys ▲ or ▼ to move among the different records of same channel.

Press “ESC” button to leave “VIEW” function and return to “Memory Access Functions Selection mode” with blinking indicator “SET” at upper-right corner.

Press direction keys ▲ or ▼ to change the blinking indicator to “SET” (SET function) or “CLR” (Memory Clear function), or to leave this function by turning the Rotary Switch to another position.

SET (SET function : Select the channels for data logging)

When the blinking indicator shows “SET”, press “←” key to enter SET function. The indicator “SET” stops blinking and another small indicator “SET” appears at left side of LCD.

Note : When there is data in the memory, you can not enter “SET” function.

To erase recorded data, please execute “CLR” function mention above.

Right after entering “SET function”, previously selected channel is shown at top of LCD.

Press direction keys ▲ or ▼ to change the channel among “T1”, “T2”, “CHA”, “CHB”, “T1T2”, “CHA T1T2” and “CHB T1T2”.

Press “←” key to confirm selection and return to function selection with indicator “SET” blinking at upper-right corner of LCD.

Press direction keys ▲ or ▼ to change the blinking indicator to “CLR” (Memory Clear function) or “VIE” (VIEW function), or to leave this function by turning the Rotary Switch to another position.

Note : When single channel (i.e. T1 or T2 or CHA or CHB) is selected, the selected channel will be automatically assigned to Main Display and overwrite the previous setting of Main Display. When multi channel (i.e. “T1 T2” or “CHA T1 T2” or “CHB T1 T2”) is selected the first channel (i.e. T1 for “T1 T2” or “CHA” for “CHA T1 T2” or CHB for “CHB T1 T2”) will be automatically assigned to Main Display and overwrite the previous setting of Main Display. If you do not want this automatic assigned channel shown in Main Display, please re-set the Main Display (see section 8.1 for setting Main Display). This resetting of Main Display does not influence the set channel(s) for data logger.

* Please refer note of 8.12 (page 15)

NOTE :
 Press "ESC" or "cancel" button or turn Rotary Switch to another position before finishing SET and CLR function ; previous setting and recorded data will remain unchanged.

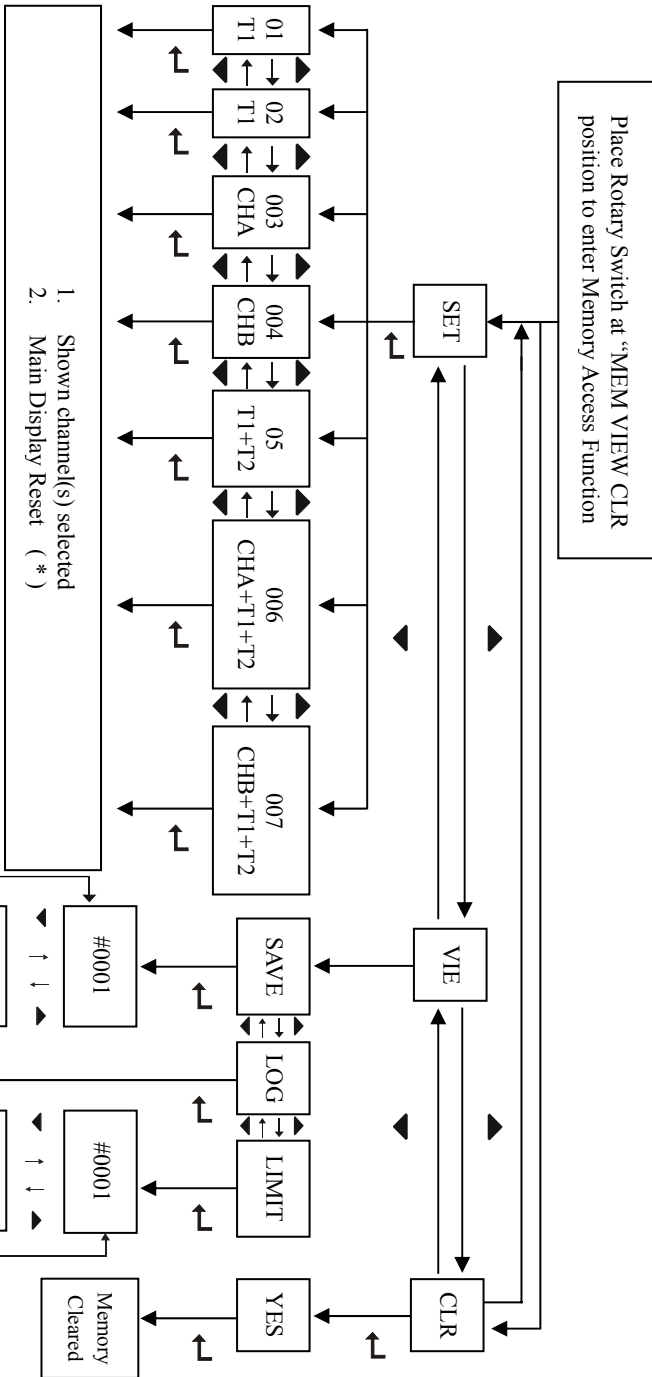

5. Turn On and Off Model 506A:

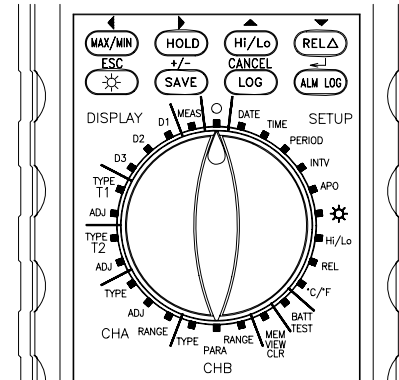

Power is off when the “Rotary Switch” points to the upper center, the position marked with “O”, turning the rotary switch to any other position automatically turns on Model 506A5. Numbers and marks appear in the LCD display.

When APO (Auto Power Off) is enabled (refer to 8.17 for enable and disable of APO), power is automatically turn off if no operation for a period of time. (Factory setting = 5 min. settable by user).

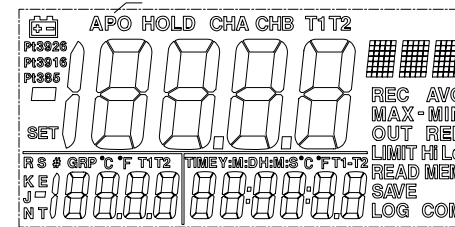

Indication of APO Enabled

6. Check battery Voltage:

Place the rotary switch at the position “BATT TEST”, main display shows the voltage of battery.

7. Measurement and Main Function of Buttons

Place the rotary switch at “MEAS” position, the meter starts to measure. Main display shows the measurement reading of the channel assigned to main display. (to select channel for main display, please refer to 8.1)

While measuring, press push buttons to change the function of main display and perform record functions.

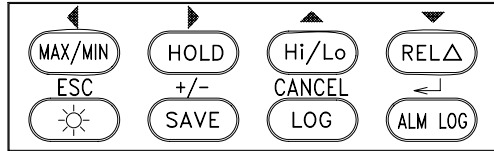

7.1 MAX/MIN : (This function only applies to the channel shown in main display)

Pressing “MAX/MIN” button, the indicator “REC” appears at right side of LCD, the meter will start to record the Maximum and Minimum values and calculate average value of measurement reading.

Press “MAX/MIN” button again each time, main display changes from current measurement reading to maximum value recorded with indicator “MAX” below “REC”, minimum value recorded with indicator “MIN” at lower right side of “REC”, the difference between maximum and minimum values with indicator “MAX-MIN” below “REC”, the average value during recording with indicator “AVG” right to “REC”, and then back to current measurement reading. Press and hold the “MAX/MIN” button for longer than 5 seconds to end the MAX/MIN recording.

7.2 HOLD : (This function only applies to the channel shown in main display)

Press the “HOLD” button, the display holds the current reading and the meter stops further measurement. Indicator “HOLD” is shown at top of the LCD.

Press the “HOLD” button again to release from the holding function and resume normal measurement.

7.3 Hi/Lo : (This function only applies to the channel shown in main display)

Press the “Hi/Lo” button, to activate the out of limit alarm function. The indicator “LIMIT” appears at right side of LCD.

When the measurement value is higher than upper limit the beep send out an intermittent sound.

When the measurement value is lower than lower limit the beep send out a continuous sound.

Press the “Hi/Lo” button again, to disable the alarm function.

Refer to 8.15 for setting upper and lower limits.

7.4 REL Δ : (This function only applies to the channel shown in main display)

REL Δ: (This function only applies to the channel shown in main display)

Press “REL Δ” to store the current value as the reference, relative value against this reference will be displayed for the measurements afterward.

7.5 ☀ :

Press this button to turn on the backlight function, press it again to turn the backlight off.

7.6 LOG (Data Logging) :

During measuring, press “LOG” button to continuously record the measurement readings of the set channels at the set time interval until the “LOG” button is pressed again.

To set the channel for LOG function, please refer to section 8.12

To set the time interval for LOG function, please refer to section 8.18

To read the logged data, please refer to section 8.12

8.11 CHB RANGE-Select the Resolution for Cannel B (CHB)

Channel B can accept the voltage signal up to 2 volts; above 2 volts display shows OL. Place the rotary switch at position “CHB RANGE”, change among “Auto (“--.-.” and “AUT” is shown in display), “0.1” (“---.” and “MAN” is shown in display) and “0.01” (“--.--.” and “MAN” is shown in display).

When “Auto” is selected, the meter will select most suitable resolution between “0.1” and “0.01”, while the other two, the reading will be fixed in the selected resolution.

8.12 MEM VIEW CLR - Selecting the channel for data logging, Read recorded data and Clear memory

There are 3 functions in this position “MEM VIEW CLR” :

1. SET function : Select the channels for data logging.
2. VIEW function : To read recorded data.
3. Memory Clear function : Clear memory and erase all the recorded data.

Place rotary switch at position “MEM VIEW CLR”, the meter enter the “Memory Access Functions Selection Mode” with LCD shows the indicator “MEM” at lower-right corner and a blinking indicator “SET” at upper-right corner.

Press direction keys ▲ or ▼ to change the blinking indicator among “SET” (SET function), “VIE” (VIEW function) and “CLR” (Memory Clear function).

To exit this function, just turn the Rotary Switch to another position.

CLR (Memory Clear function : Clear memory and erase all the recorded data)

When the blinking indicator shows “CLR”, press “ ← ” key to enter Clear function. The blinking indicator changes to “YES”.

Press “ ← ” key to clear memory and erases all the data recorded in the memory (this will take some seconds), and return to “Memory Access Functions Selection mode” with blinking indicator “SET” at upper-right corner.

Or press “ESC” key to abort the job and keep the data in the memory unchanged, and return to “Memory Access Functions Selection mode” with blinking indicator “SET” at upper-right corner.

Press direction keys ▲ or ▼ to change the blinking indicator to “SET” (SET function) or “VIE” (VIEW function), or to exit this function by turning the Rotary Switch to another position.

VIE (VIEW function : to read recorded data)

There are 3 sets of data you can choose to read, namely “SAVE”, “LOG” and “LIMIT”, (corresponding to the functions of buttons “SAVE”, “LOG” or “ALMLOG”, respectively. Please refer to section 7.6, 7.7, 7.8 for the functions of these buttons.)

When the blinking indicator shows “VIE”, press “ ← ” key to enter VIEW function. The blinking indicator “VIE” disappears. Indicators “READ MEM” and “SAVE” are shown at lower-right corner of LCD.

8.9 CHB TYPE-Select the Unit for Channel B

CHB only shows the voltage, and the unit represented by this voltage has to be given. At position "CHB TYPE", change the unit with upward (▲) or downward (▼) direction buttons among AAA, →°C→ppt→μs→ms→s→FPM→%RH→%→ppm→mV→V→μA→mA→A→Ohm.

The first unit, AAA, can be redefined by user for other special unit, see next section. Press the confirm button (↵) to select the unit. The selection is kept even power turned off.

CHB is for a transducer with output of 1 mv = 1 "unit".
CHB always measures the input voltage with mV.

The "unit" is only a human readable indicator for the convenience of user, it does not change the measurement.

The "unit" can be set as "mV" or "V" or "%RH" or "%" or "Ohm" or "ABC", and it only make sense when it is set according to the output property of the transducer.

For example if we connect a humidity transducer with output 1 mV = 1 %RH to the CHB (channel B) of the meter, the "unit" should be set as "%RH". If user does not do so, then the unit becomes meaningless, but the measurement will not influenced.

8.10 CHB PARA-Create Special Unit for Channel B (CHB)

Changing each individual character of "AAA" to one of following can create special units. (Characters available: upper case characters A to Z, lower case a to z, o, /, %, μ, dot and blank space).

Place rotary switch at position "CHB PARA", This user defined unit (set as "AAA" when shipment) shows at right-upper corner of LCD with the left character blinking. The blinking character can be changed with upward (▲) or downward (▼) direction buttons.

With right (▶) or left (◀) direction buttons, the blinking can be moved to another character. After all 3 character are changed to the desired ones, press confirm button (↵).

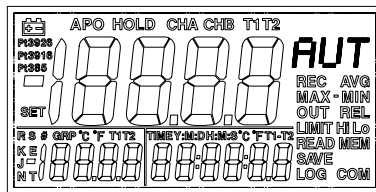

(AUTO)

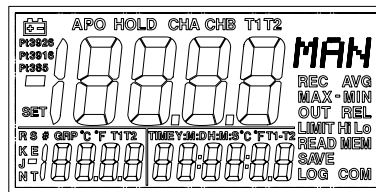

(MANUAL)

7.7 SAVE :

SAVE : This function only apply to the channel shown in main display. And not function when LOG function is set as multi-channel logging.)

During measuring, press "SAVE" button to record current measurement reading of the channel shown in Main Display and time.

To read the recorded data, please refer to section 8.12

To set the channel for Main Display please refer to section 8.1

To set the channel for LOG function please refer to section 8.12

7.8 ALMLOG : (This function only apply to the channel shown in main display. And not function when LOG function is set as multi-channel logging)

Every time when the measurement reading of the channel shown in Main Display the Alarm Log function records the first measurement reading which is out of limits and time, when the measurement value returns to within the limits the last out of limit data and time will also be recorded.

Press the "ALMLOG" button, to activate the alarm log function, and the indicators "LIMIT" and "LOG" are shown at lower-right corner of the LCD.

Press the "ALMLOG" button again to disable this function.

To read the recorded data, please refer to section 8.12

To set the channel for Main Display please refer to section 8.1

To set the channel for LOG function please refer to section 8.12

8. System Setting and second Functions of Buttons:

Except these 3 positions mentioned above, all other position are for system setting, the indicator "SET" shows at left side of LCD when place the rotary switch at any of these system setting positions. And 2nd functions of buttons are active.

8.1 D1-Setting the Main Display

Main display can be set to show the reading of any of the 4 channels. Place rotary switch at position "D1", and select the channel with "right (▶)" or "left (◀)" direction keys to change the channel. "D1", name of active channel is shown at top of LCD. Press "CANCEL" button to back to previous setting. Press "ESC" button to abort change and exit the setting mode with previous setting remains unchanged. Confirm selection and exit setting mode by pressing "confirm (↵)" button.

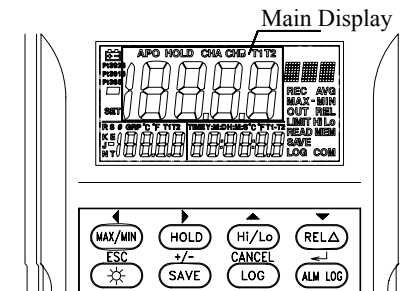

8.2 D2-Setting Second Display (Lower-Left Display)

Second display can be set to show the reading of T1 or T2. When the power is turn on, the meter remains in the previous setting. Turn the rotary switch to the position “D2”, and use right (▶) or left (◀) direction buttons to change between T1 and T2.

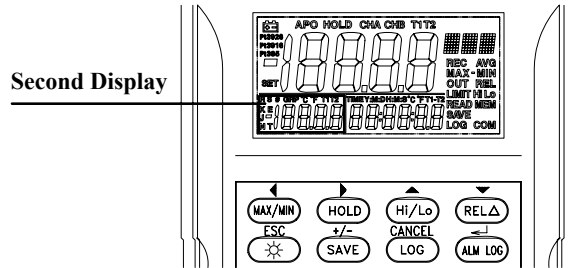

8.3 D3-Setting Third Display (Lower-Right Display)

Third display can be set to show the value of T1-T2, Date (YY: MM: DD) and time (HH:MM:SS). When the power is turn on, the meter remains in the previous setting. Turn the rotary switch to the position “D3”, and use right (▶) or left (◀) direction buttons to change between T1 and T2.

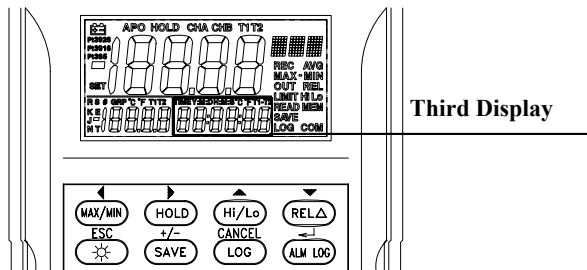

8.4 T1 TYPE and T2 TYPE-Selecting the Types of Thermocouple for T1 or T2

Both T1 and T2 can accept the thermocouples of type K, J, T, E, R, S and N. When the power is turn on, the meter remains in the previous setting. Turn the rotary switch to the position “T1 Type” or ”T2 Type”, current selection is shown at upper-right corner of LCD, adjacent to unit of temperature, change type of thermo couple with upward (▲) or downward (▼) direction buttons after right type is shown, and press confirm key (↵) to select.

8.5 T1 ADJ and T2 ADJ-Setting the Off-Set Adjustment for T1 or T2

If the offset error of your thermo couples, and to which socket those particular thermocouples are known, the offset adjustments can be set to each of T1 and T2 for compensating the off-set error.

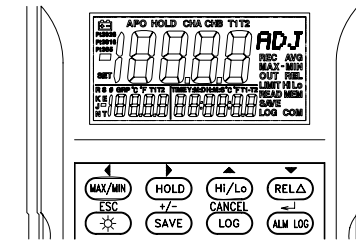

8.6 CHA TYPE-Selecting the Types of RTD for CHA

Besides accepting the RTD of type Pt 385, Pt3916 and Pt3926, this meter can also display the resistance value in ohm (Ω) of the sensor. When the power is turn on, the meter remains in the previous setting. Turn the rotary switch to the position “CHA-Type”, current selection is shown at left side of LCD for RTD sensors and right hand side, for ohm. Change the types with upward (▲) or downward (▼) direction buttons after right type is shown, press return key (↵) to select.

8.7 CHA ADJ-Setting the Off-Set Adjustment for RTD

If the off-set error of your RTD is known, the off-set adjustments to the channel A (CHA). Place the rotary switch at positions “ADJ” just below “CHA-Type”.

Select the digit you want to adjust with right (▶) or left (◀) direction buttons, (Setting of the adjustment value is done one individual digit after the other). Change the value of blinking digit with upward (▲) or downward (▼) direction buttons. After reach desired value, press return key (↵) to confirm.

8.8 CHA RANGE-Select the Resolution for Channel A (CHA)

Place the rotary switch at position “CHA RANGE”, change among “Auto (“--.-“ and “AUT” is shown in display) and “0.1” (“---.-“ and “MAN” is shown in display) and “0.01” (“--.-“ and “MAN” is shown in display).

When “Auto” is selected, the meter will select most suitable resolution between “0.1” and “0.01”, while the other two, the reading will be fixed in the selected resolution.

