

# OPERATION MANUAL OF MODEL TH2817 PRECISION LCR METER

**Changzhou Tonghui Electronic Co., Ltd**

**Add: No.3, Tianshan Road, Changzhou New District, Jiangsu**

**Tel: (0519)85132222, 85113342, 85109592**

**Fax: (0519)85109972**

**Postcode: 213022**

**Http:\\ [www.tonghui.com.cn](http://www.tonghui.com.cn)**

**E-mail: [sales@tonghui.com.cn](mailto:sales@tonghui.com.cn)**

# Contents

# **DANGER**

The highest external DC bias voltage is 100V. When external dc bias voltage is applied, the high voltage exists between the test terminals of the meter. Special care should be taken when carrying out test to avoid injury of human body caused by electrical shock. When making test with external bias voltage applied, please do not contact directly or plug in/draw out the component under test on the test fixture or test cable because leads of the tested component are of high voltage.

# **WARNING**

To avoid electric shock hazard, please make sure that phase line, zero line and ground line are connected correctly before the meter is plugged into an outlet. The instrument chassis and cabinet must be connected to a safety earth ground to avoid the cover to be electrified.

# **WARNING**

Only qualified maintenance person can remove instrument cover to make maintenance and adjustment. The plug of power supply should be drawn out when replacing components. Take care not to contact the parts with 220V when making maintenance to avoid the hazard of electrical shock. It is absolutely prohibited to perform normal measurement when the cover is removed (except for maintenance and adjustment).

# **ATTENTION**

Do not make any component replacement and internal adjustments when the meter is switched on to avoid unnecessary damage of components or the instrument.

# **ATTENTION**

The calibration of the instrument should be done by professional person, and required operation on the manual should be completely followed. Should trouble occur, it must be returned to the company or those qualified service office for service and repair.

## 1.1 Introduction

TH2817 is an high precision impedance test instrument with wide test range. The instrument provides six typical test frequencies of 100 Hz, 120 Hz, 1 kHz, 10 kHz, 40 kHz and 100 kHz and three test levels of 0.1V, 0.3V and 1.0V for convenient choice, and can measure various parameters such as inductance L, capacitance C and resistance R. This instrument which merges powerful functions, excellent performances and simple operation into a whole can satisfy both the need for fast test in factories, and the requirement of high precision and stable measurement in laboratory. Meanwhile, the interfaces of Handler and RS-232c make it possible for the instrument to work with automatic sorting machine and communicate with computer. The measurement conditions and values can be printed directly through the printer interface. TH2817 really provides customers an instrument of high performances but low price.

The basic measurement circuits are as follows: sine signal generator with variable frequencies, test level regulator, precision range resistors, phase detector and A-D converter with balanced charges. Measurement, calculation, functions and display are controlled by the microprocessor.

The instrument provides various test conditions such as:

- Test frequency – six typical test frequencies 100 Hz, 120 Hz, 1 kHz, 10 kHz, 40 kHz and 100 kHz;
- Test signal level – 0.1V, 0.3V and 1.0V;
- Test speed – fast, medium and slow;
- Correction – the meter can perform open and short corrections so as to eliminate the influence of stray capacitor and cable resistance around test terminals and improve accuracy.
- Level monitor – level actually applied upon device under test maybe different with that set in the program due to mismatch between the impedance under test and the signal source impedance. The function allows you to monitor the actual voltage level across the device under test and the actual current level through the device under test.

The instrument provides three kinds of output data and corresponding sorting function:

- Direct – display the value of tested component directly;
  - Absolute deviation – difference between the measured value and the nominal value;
  - Percent deviation – difference between the measured value and the nominal value displayed as a percentage of the nominal value;
- Sorting – three sorting modes of direct, absolute and percent can be selected ;  
and four bins are available: NG means no good and P1, P2 and P3 mean pass1, pass 2 and pass 3 separately;
- Print interface – each value of measurement and internal setup parameters can be printed by a printer with a standard interface;
- Serial interface – RS-232C provides great convenience for communications between the instrument and computers. All functions and parameters of the meter can be set through the interface by which functions of the keyboard can almost be replaced;
- Handler interface – to enable the instrument to operate synchronized with mechanical equipment, test and sort components and send sorting results to mechanical equipment.

## 1.2 Technical Specifications

### 1.2.1 Measurement Parameters

Capacitance C, inductance L, resistance R and impedance Z can be displayed by the display A window with maximum five digits.

Dissipation factor D and quality factor can be displayed by the display B window with maximum five digits.

The instrument provides two kinds of equivalent circuits in which Z, D and Q have the same values while C, L and R have different values under the two equivalent circuits. The relations between the two equivalent circuits are discussed in section 2.3.4.

#### 1.2.2 Measurement Terminals

There are five terminals, namely HD, HS, LS, LD and GND.

#### 1.2.3 Test Frequency

Test frequency: six frequency points of 100 Hz, 120.120 Hz, 1 kHz, 10 kHz, 40 kHz and 100 kHz.

Accuracy of frequency: 0.02%.

Note: 120.120 Hz is regarded as 120 Hz in this manual.

#### 1.2.4 Display Range

L: 0.0001 $\mu$ H ~ 99999H  
C: 0.0001pF ~ 99999 $\mu$ F  
Z/R: 0.0001 $\Omega$  ~ 99999M $\Omega$   
D/Q: 0.0001 ~ 99999  
 $\Delta\%$ : 0.01% ~ 99999%  
D/Q ( ppm mode): 1ppm ~ 99999ppm

#### 1.2.5 Measurement Accuracy

C:  $0.05\% (1+C_x/C_{max}+C_{min}/C_x) (1+D_x) (1+k_s+k_v+k_f)$ ;  
L:  $0.05\% (1+L_x/L_{max}+L_{min}/L_x) (1+1/Q_x) (1+k_s+k_v+k_f)$ ;  
Z:  $0.05\% (1+Z_x/Z_{max}+Z_{min}/Z_x) (1+k_s+k_v+k_f)$ ;  
R:  $0.05\% (1+R_x/R_{max}+R_{min}/R_x) (1+Q_x) (1+k_s+k_v+k_f)$ ;  
D:  $\pm 0.0003 (1+Z_x/Z_{max}+Z_{min}/Z_x) (1+D_x+D_x^2) (1+k_s+k_v+k_f)+0.0002$ ;  
Q:  $\pm 0.0005 (1+Z_x/Z_{max}+Z_{min}/Z_x) (Q_x+1/Q_x) (1+k_s+k_v+k_f)$ .

Notes: 1. D and Q are absolute deviations and others are percent deviations;

2. Those with subscript  $_x$  mean measurement values of the parameters, those with subscript  $_{max}$  mean maximum values and  $_{min}$  mean minimum values;

3.  $k_s$  is the speed factor,  $k_v$  is the level factor and  $k_f$  is the frequency factor;

4. In order to gain high measurement accuracy, you should make open and short correction again when the test fixture or conditions are changed.

##### 1.2.5.1 Speed Factor $k_s$

Fast:  $k_s = 4$ ;

Medium:  $k_s = 1$ ;

Slow:  $k_s = 0$ .

1.2.5.2 □ Maximum and Minimum Values For Different Ranges

**Table 1-1 Maximum and Minimum Values**

Parameter	Auto Range	Range Hold				
		Range 0	Range 1	Range 2	Range 3	Range 4
$C_{max}$	80 $\mu\text{F}/f$	1000 pF/f	0.1 $\mu\text{F}/f$	1 $\mu\text{F}/f$	10 $\mu\text{F}/f$	80 $\mu\text{F}/f$
$C_{min}$	150 pF/f	150 pF/f	1900 pF/f	10 nF/f	100 nF/f	1 $\mu\text{F}/f$
$L_{max}$	159 H/f	159 H/f	25.3 H/f	2.53 H/f	253 mH/f	25.3 mH/f
$L_{min}$	0.32 mH/f	2.53 H/f	0.25 H/f	25.3 mH/f	2.53 mH/f	0.32 mH/f
$Z_{max}$	1 M $\Omega$	1 M $\Omega$	159 k $\Omega$	15.9 k $\Omega$	1.59 k $\Omega$	159 $\Omega$
$Z_{min}$	15.9 $\Omega$	15.9 k $\Omega$	1.59 k $\Omega$	159 $\Omega$	15.9 $\Omega$	1.59 $\Omega$

Note:  $Z_{max} = R_{max}$ ,  $Z_{min} = R_{min}$

The unit of f is kHz, when  $f > 10$  kHz, range 0 is not in use; When  $f > 10$  kHz and measurement range is set to auto,  $C_{min} = 1000$  pF/f,  $L_{max} = 25.3$  H/f,  $Z_{max} = 159$  k $\Omega$ .

1.2.5.3 □ Level Factor  $k_v$

When  $V = 0.3\text{V}$  or  $1.0\text{V}$ ,  $k_v = 0$ ;

When  $V = 0.1\text{V}$ ,  $k_v = 1.5$ .

1.2.5.4 □ Frequency Factor  $k_f$

When  $f = 100$  Hz, 120 Hz or 1 kHz,  $k_f = 0$ ;

When  $f = 10$  kHz,  $k_f = 0.5$ ;

When  $f = 40$  kHz,  $k_f = 2$ ;

When  $f = 100$  kHz,  $k_f = 3$ .

1.2.6 □ Measurement Level

Three levels are available: 0.1 V, 0.3 V and 1.0 V (effective value);

Level accuracy:  $\pm(8\% \times \text{set value}) (1+k \cdot f)$

Note: The set value of the measurement level is the value set when test terminals are opened (HD and HS should be connected).

Here f is measurement frequency with the unit of kHz;

When Range = 0,  $k = 0.25$ ;

When Range = 1,  $k = 0.025$ ;

When Range = 2, 3 or 4,  $k = 0.005$ .

Due to the output impedance of the signal source, the actual level applied upon the component under test may be different from the set value. Select V/I display mode, the actual voltage across the device and current through the device are displayed.

1.2.7 □ Measurement Speed

Fast: 20 times/sec.;

Medium: 5.1 times/sec.;

Slow: 1.5 times/sec.

The actual speed differs with different measurement conditions such as frequency, component value, display mode (Direct,  $\Delta$  or  $\Delta\%$ ), equivalent circuit, trigger mode, range select mode, average times and so on.

The typical speeds for Fast, Medium and Slow are given under the following measurement conditions:

- Frequency: 1 kHz;
- Trigger mode: Continuous;
- Range mode: Hold;
- Display parameters: C&D;
- Average times: 1 time.

When some of the functions are in use, test speed will properly be reduced:

- a) When print interface is used, the measurement speed varies with the speed of printer;
- b) When RS-232C interface is used, it will take 10 to 20 ms additional time. Actual time is determined by the baud rate of the instrument;
- c) The sorting function will spend 5 to 8 ms.

### 1.3 Functions

#### 1.3.1 Average of Measurement Values

The instrument can calculate the average value of the measurement values and the number of values averaged can be set from 1 to 99.

#### 1.3.2 Correction

Open correction capability cancels errors due to the stray admittance (G, B) in parallel with the device under test.

Short correction capability corrects for the residual impedance (R, X) in serial with the device under test.

#### 1.3.3 Equivalent Circuit

The measurement value of the device under test can be outputted in both series and parallel equivalent circuit models.

#### 1.3.4 Measurement Mode

Continuous: the instrument continuously repeats measurements and displays the values after each measurement;

Single: usually the instrument is in the wait for trigger state, the instrument performs a single measurement every time a “Start” signal from the keyboard or from the interface is received. Then it returns to wait for trigger state again and waits for the next “Start” signal.

#### 1.3.5 Range Hold

The instrument is set to the Auto mode when it is switched on. When the measurement range is set to the Hold mode, the impedance range is fixed at the current range setting.

In the Hold mode, if the measured impedance is out of the effective measurement range, the instrument will not meet its measurement accuracy specification.

#### 1.3.6 □ Display Mode

Display window A has four display modes:

- Direct (actual measurement value of the component under test);
- $\Delta$  (absolute deviation between the actual measurement value and the nominal value);
- $\Delta\%$  (deviation between the actual measurement value and the nominal value displayed as a percentage of the nominal value);
- V/I (effective values of the voltage across the device under test and the current through the device under test).

#### 1.3.7 □ Sorting Function

The instrument provides four sorting bins which are described as NG, P1, P2 and P3. NG means NO GOOD and P1, P2 and P3 means PASS 1, PASS 2 and PASS 3.

There are three sorting modes: direct (DIR), absolute deviation (ABS) and percent deviation (PER).

The sorting result will be indicated by the sorting indicating lamp in the front panel, and sorting result can be outputted by the Handler interface when the instrument works in Single mode and its Handler interface is in “ON” state.

#### 1.3.8 □ Print Function

The internal parameters, sorting limits and measurement values can be printed out through the print interface by the printer with a standard interface.

#### 1.3.9 □ RS-232C Serial Interface

The instrument can be operated by a computer through the serial interface instead of the keyboard in the front panel, at the same time the instrument can send out the measurement values to other equipments.

#### 1.3.10 □ Handler Interface

When sorting function is selected, Handler interface is set to “ON” state and the instrument works in Single trigger mode, the instrument will output the bin sorting results, the signal of busy with A/D conversion and calculation, and the signal of End of A/D conversion. The instrument can be triggered by the Handler interface.

#### 1.3.11 □ Other Functions

Except for the described functions, the instrument also provides following functions:

1. Automatically select the measurement parameter of L, C and R;
2. Display the measurement values without Open or Short correction;
3. Display the measurement values of D and Q in the ppm mode;
4. Select the alarm function and control the volume of alarm;
5. Select the bin (P1, P2, P3 or NG) to be alarmed.

#### 1.4 □ Front and Rear Panel

#### 1.4.1 A Tour of the Front Panel

The schematic drawing of the front panel can be seen on the next page.

Description of the front panel:

No.	Name	Description
1	Main Parameters (or “Display A” in this manual)	Display the measurement values of C, L, Z and R. Three display modes can be selected: Direct, Absolute deviation $\Delta$ and percent deviation $\Delta\%$ . It can also display information when setting parameters.
2	Units of Main Parameters	Indicate the units of main parameter in Direct and Absolute modes.
3	Sub Parameters (or “Display B” in this manual)	Display the measurement values of D and Q. It can also display information when setting parameters.
4	Units of Sub Parameters	Indicate which sub parameter is now measured. When the sub parameters are displayed in ppm mode, the ppm LED indicator is ON.
5	State Indication	For more information, refer to paragraph 2.1.
6	Frame Terminal (GND)	Used for measurements that require guarding. The Frame Terminal is tied to the instrument’s chassis, and it is connected with the protective earth ground of power supply.
7	Test Terminals	Provide 4-terminals for measurement of component: HD (High Drive of current): Test signal is outputted through HD. Voltage, frequency and wave form of test signal can be measured at HD by voltmeter, frequency meter and oscillograph etc. HS (High Sense of voltage): sample the high potential of the device under test. LS (Low Sense of voltage): sample the low potential of the device under test. LD (Low Drive of current): the current flowing through the device under test is sent to the current measuring part of instrument. HD and HS should be connected to one lead of the device under test and LD and LS should be connected to another lead.
8	Trade Mark & Model	TONGHUI, TH2817 Precision LCR Meter
9	Keyboard	Functions and measurement conditions of the instrument can be selected and controlled by the 6-button keyboard.
10	Sorting Indication	When sorting is ON, the LEDS indicate the sorting result.
11	Power ON/OFF	Power ON/OFF Switch. In the “ON” position all operating voltages are applied to the instrument. In the “OFF” position no operating voltages are applied to the instrument.

Table 1-2 Description of Front Panel



#### 1.4.2 Description of the Rear Panel

Description of the rear panel:

No.	Name	Description of Function
1	RS-232 Serial Interface (9-Pin)	Provide serial interface between the instrument and peripheral equipments. Parameters, instructions and measurement results can be sent and received through the interface.
2	Handler Interface (9-Pin)	By using the Handler Interface, the instrument can easily be combined with a component handler, and a system controller to fully automate component testing, sorting, and quality control data processing.
3	Print Interface (25-Pin)	By using the Print Interface, the instrument can be connected to a printer with a standard print interface. All setup parameters, measurement values and sorting results can be printed.
4	Fuse Holder	Used the correct fuse to protect the instrument, 1A 250Vac.
5	LINE Input Receptacle	AC power cord receptacle.
6	Nameplate	Used to indicate following information: License No., date, serial number and manufacturer.

Table 1-2 Description of Rear Panel

#### 1.5 Operating Environment

##### 1.5.1 Temperature and Humidity

Temperature: 0°C ~ 40°C;

Humidity: ≤90%R.H. at 40°C.

##### 1.5.2 Power Supply

Voltage: 198 ~ 242V;

Frequency: 45 ~ 55Hz;

Power: ≤30W.

##### 1.5.3 Dimensions

390(W) by 160(H) by 420(D) (mm)

##### 1.5.4 Weight

Weight approximately 5 kg .

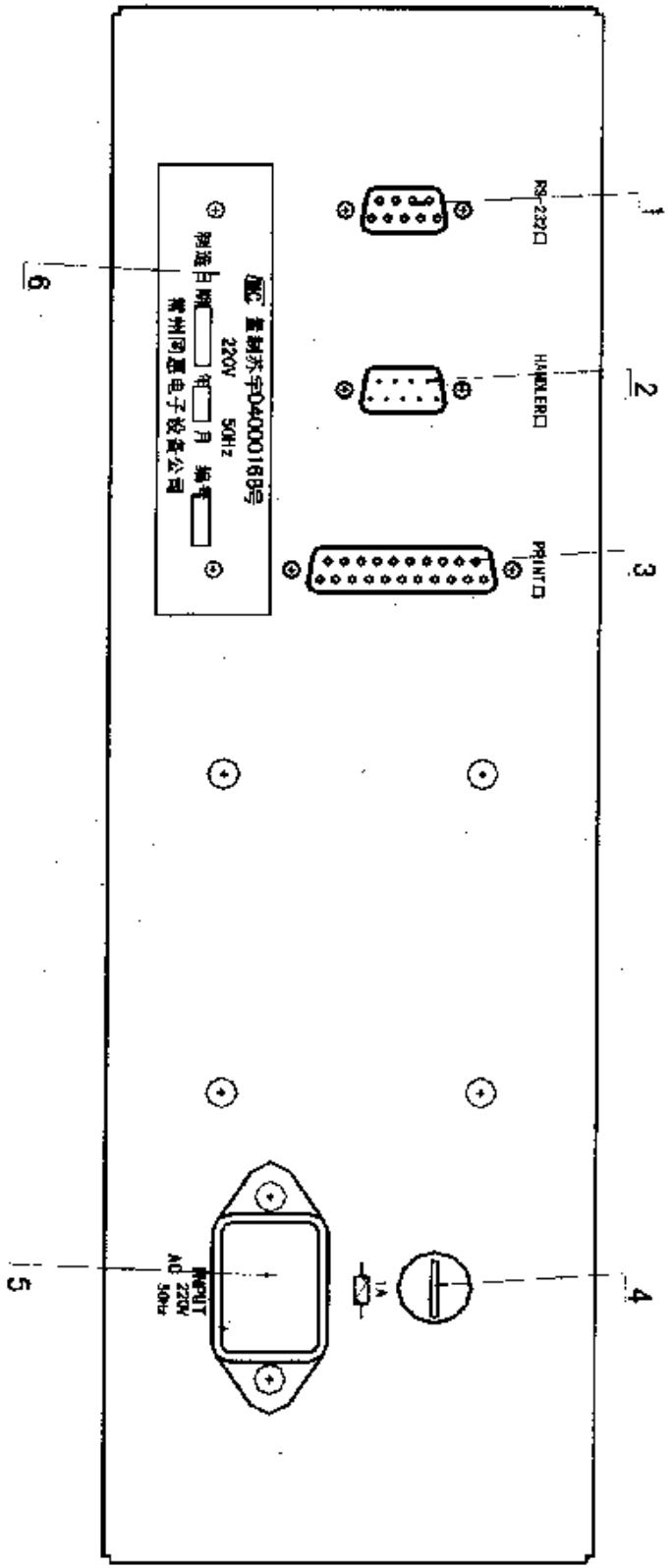

## 2 Chapter Operation Instruction

### 2.1 Keyboard and Function of the Meter

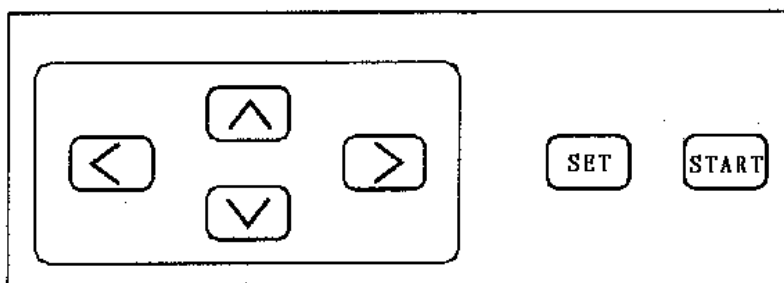

Figure 2-1 Keyboard of TH2817

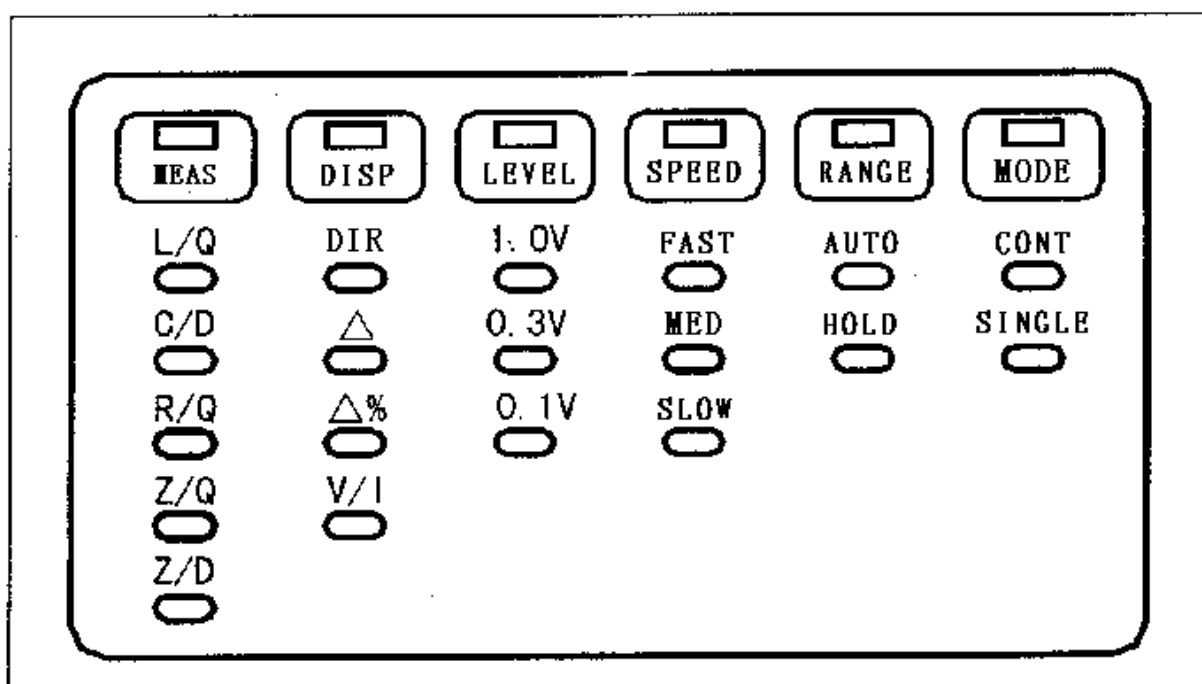

Figure 2-2 Measurement States of TH2817

TH2817 has only six keys shown as Figure 2-1. These keys are used to select controls and set parameters. The keys have different functions in different conditions. There are three main menus. Each menu will be discussed in this chapter.

**First Menu:** In this menu the instrument performs normal measurements, cursor keys can be used to select measurement parameters, display mode, test level, speed, range and trigger mode.

**Second Menu:** The instrument enters into the second menu by pressing the **SET** key once when the instrument is in the first menu. In this menu you can set the test frequency, averaging rate, equivalent circuit, and so on.

**Third Menu:** The instrument enters the third menu by pressing the **SET** key once again when the instrument is in the second menu. You should press the **SET** key twice if the instrument is in the first menu. All the limits and nominal parameters can be inputted in this menu. If you press the **SET** key again in the third menu, the instrument will return to the measuring state (or the First Menu).

Functions in each menu are listed as follows:

1. The First Menu (or in the measuring state): All functions of this menu are indicated on the front panel directly, and can be controlled by using the four cursor keys, “**^**”, “**v**”, “**□**” and “**▢**”.

- A. Measurement Parameters: L/Q, C/D, R/Q, Z/Q and Z/D can be selected to be measured by the instrument;
- B. Display Mode: Dir(Direct),  $\Delta$ (Absolute deviation),  $\Delta\%$ (Percent deviation) and V/I (Voltage/Current) can be selected to displayed in the window of Display A;
- C. Measurement Level: 1.0V, 0.3V and 0.1V;
- D. Measurement speed: FAST, MED(medium) and SLOW;
- E. Range Mode: AUTO and HOLD;
- F. Trigger Mode: CONT(continuous) and SINGLE.

2. The Second Menu:

- A. Measurement Frequency (FRE--): 100 Hz (0.1000), 120 Hz (0.1201), 1 kHz (1.0000), 10 kHz (10.000), 40 kHz (40.000), 100 kHz (100.00);
- B. Average Number (AVE--): 1~99 (1, 2, ....., 99);
- C. Equivalent Circuit (EQU--): Series Mode (SER) and Parallel mode (PAR);
- D. D, Q in PPM Mode (PDQ--): On (ON) and Off (OFF);
- E. Volume (VOL--): High (Hi), Low (Lo) and Off (OFF);
- F. Alarm Bin (ALA--): PASS 1 (P1), PASS 2 (P2), PASS 3 (P3), NO-GOOD (NG);
- G. Auto LCR (LCR--): On (ON) and Off (OFF);
- H. No Correction (NCL--): On (ON) and Off (OFF);
- I. Serial Interface (RSC--): On (ON) and Off (OFF);
- J. Print Interface (PRN--): On (ON) and Off (OFF);
- K. Handler Interface (HAN--): On (ON) and Off (OFF);
- L. Sorting Mode (SOR--): Percent deviation  $\Delta\%$  (PER), Absolute deviation  $\Delta$  (ABS), Direct (DIR) and off (OFF);
- M. Correction (CLR--): Open Correction (OPEN) and Short Correction (SHORT).

**Note: Characters inside the parenthesis are displayed characters**

**by Display A and Display B.**

3. The Third Menu:

- A. High Limit of Bin 1 (P1<sup>-</sup> --);
- B. Low Limit of Bin 1 (P1<sub>-</sub> --);
- C. High Limit of Bin 2 (P2<sup>-</sup> --);

- D. Low Limit of Bin 2 (P2\_--);
- E. High Limit of Bin 3 (P3\_--);
- F. Low Limit of Bin 3 (P3\_--);
- G. High Limit of D (D\_--);
- H. Low Limit of Q (Q\_--);
- I. Nominal (STD--).

### 2.2 Conversion of Menus

Previous paragraph described the menus and the functions of each menu. The conversions from one menu to another menu are described as follows:

The instrument is in the First Menu when it is switched on. You can set the functions in this menu. If you want to set the functions in other menus, you should change to the corresponding menu first. Following figure tells us how to change the menu:

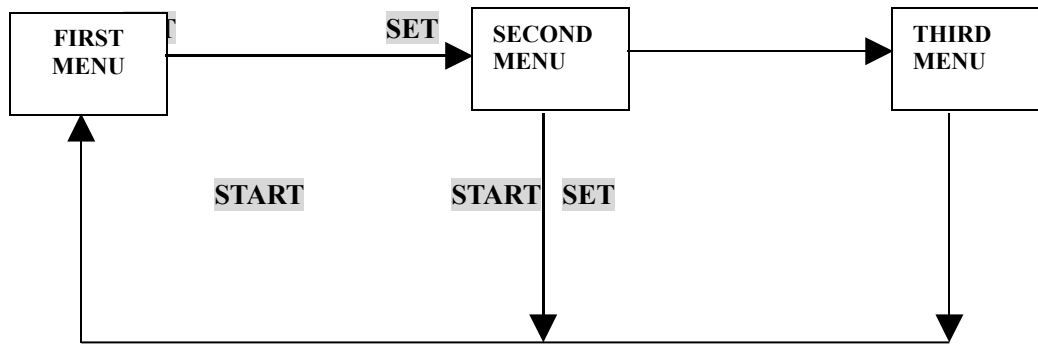

Figure 2-3 Conversion of Menus

Press  $\wedge$ ,  $\vee$ ,  $\square$  and  $\square$  in each menu, you can select and control the functions of the instrument. You should return to the First Menu (Measurement State) to continue your measurement after functions setup.

Descriptions of Figure 2-3:

When SET key is pressed in the First Menu (Measurement State), the instrument enters into the Second Menu. The functions except for those in the first menu can be found in this menu, such as Frequency Setup. Press START key in the Second Menu, you will return to the First Menu (Measurement State). Press SET key in the Second Menu, you will enter into The Third Menu, in this menu you can set the sorting limits and nominal value. Press START key in the third menu, you will return to the First Menu (Measurement State). If SET key is pressed instead of START key in the third menu, you can also return to the First Menu (Measurement State).

### 2.3 Functions Setup in the First Menu

Functions in the First Menu (Measurement State) are shown in Figure 2-2.

All functions can be set by the four cursor keys  $\wedge$ ,  $\vee$ ,  $\square$  and  $\square$ . All functions have their states. For example, “Measurement Parameter” and “Measurement Frequency” are functions, while “L/Q”, “C/D”, “R/Q”, “Z/Q” and “Z/D” are states of “Measurement Parameter”, “100 Hz”, “120 Hz”, “1 kHz”, “10 kHz”, “40 kHz” and “100 kHz” are states corresponding to “Measurement Frequency”.

In the First Menu (Measurement State), there are six function items: “MEAS”, “DISP”, “LEVEL”, “SPEED”, “RANGE” and “MODE”, which are indicated by six LED lamps respectively. The LED lamp indicates which function item is to be set, so only one LED lamp is ON at the same time.

The default states of functions in the First Menu (Measurement State) are as follows:

Function	STATE
MEAS:	C/D
DISP:	DIR
LEVEL:	1.0V
SPEED:	SLOW
RANGE:	AUTO
MODE:	CONT

Use  $\square$  and  $\square$  keys to select a function, a function is selected when its led lamp is ON. Then you can use  $\wedge$  and  $\vee$  keys to select the state of this function until the corresponding led lamp of the state is ON, which means the state is selected.

### 2.3.1 $\square$ Measurement Parameter

Parameters to be measured by TH2817 are as follows:

L/Q: Inductance L and Quality factor Q

C/D: Capacitance C and Dissipation factor D

R/Q: Resistance R and Quality factor Q

Z/Q: Absolute value of impedance Z and Quality factor Q

Z/D: Absolute value of impedance Z and Dissipation factor D

Measurement values of L, C, R and Z are displayed by the window of Display A while D and Q are displayed by the window Display B.

Units of all parameters are as follows:

L:  $\mu\text{H}$ ,  $\text{mH}$  and  $\text{H}$ ;

C:  $\text{pF}$ ,  $\text{nF}$  and  $\mu\text{F}$ ;

R and Z:  $\Omega$ ,  $\text{k}\Omega$  and  $\text{M}\Omega$ .

Z, D and Q have the same measurement values in series or parallel equivalent circuit, while L, C and R have different measurement values in different equivalent circuits. The relation of the two equivalent circuit modes is shown in Table 2-5.

Z displayed by the window Display A is always positive ( $\geq 0$ ). C, L and R may have negative values. When measuring C&D, the negative value of C means that the component under test has the characteristics of an inductor. When measuring L&Q, the negative value of L means that the component under test has the characteristics of a capacitor. In theory, the resistance of R has the positive value. However in some cases, value of R may be negative, which is generated due to excess correction. In order to eliminate the negative value of R, correct corrections are needed.

Sub parameter D is the reciprocal of Q. Assume that  $P_R$  is the energy consumed by the equivalent resistor of tested component,  $P_C$  is the energy stored by the equivalent capacitor and  $P_L$  is the energy stored by the equivalent inductor, then D and Q can be given by

$$D = \frac{P_R}{P_C} \quad D = \frac{P_R}{P_L} \quad 2-1$$

$$Q = \frac{1}{D} \quad 2-2$$

According to the equation (2-1), we can use the following equations to calculate D in series and parallel equivalent circuit models.

$$D = \frac{R_S}{|X_S|} \quad D = \frac{|X_P|}{R_P} \quad 2-3$$

$X_S$  is the reactance of the component in series equivalent circuit, while  $X_P$  is the reactance of the component in parallel equivalent circuit.

Equation (2-3) shows that D and Q have the same sign with that of  $R_S$  and  $R_P$ , and have no relation with the sign of  $X_S$  or  $X_P$ .

### 2.3.2 □ Display Mode

TH2817 provides four kinds of display modes:  
DIR,  $\Delta$ ,  $\Delta\%$  and V/I.

#### 2.3.2.1 □ DIR Mode

In DIR mode, the measurement values of the device under test can be read directly from the instrument. For L/Q, inductance and quality factor are displayed; For C/D, capacitance and dissipation factor are displayed; For R/Q, resistance and quality factor are displayed; For Z/Q, absolute value of impedance and quality factor are displayed; For Z/D, absolute value of impedance and dissipation factor are displayed.

In DIR mode, the measurement values displayed in the window Display A have their corresponding units. The following units are used by the instrument:

pF, nF and  $\mu$ F for C;  
 $\mu$ H, mH and H for L;  
 $\Omega$ , k $\Omega$  and M $\Omega$  for Z & R.

Table 2-1 shows that different units are used in different ranges with different resolutions:

Parameter	Range	Unit	Resolution
C	$< 1.75 \times 10^{-9} \text{F}$	pF	0.0001pF
C	$1.75 \times 10^{-9} \text{F} \leq C \leq 1.75 \times 10^{-6} \text{F}$	nF	0.0001nF
C	$> 1.75 \times 10^{-6} \text{F}$	$\mu$ F	0.0001 $\mu$ F
L	$< 1.75 \times 10^{-6} \text{H}$	$\mu$ H	0.0001 $\mu$ H
L	$1.75 \times 10^{-3} \text{H} \leq L \leq 1.75 \text{H}$	mH	0.0001mH
L	$> 1.75 \text{H}$	H	0.0001H
R/Z	$< 1.75 \times 10^3 \Omega$	$\Omega$	0.0001 $\Omega$
R/Z	$\leq 1.75 \times 10^6 \Omega, \geq 1.75 \times 10^3 \Omega$	k $\Omega$	0.0001k $\Omega$
R/Z	$> 1.75 \times 10^6 \Omega$	M $\Omega$	0.0001M $\Omega$

Table 2-1 Units and resolutions for different ranges

### 2.3.2.2 □ Deviation Measurement

TH2817 provides two types of deviation measurements. They are absolute deviation measurement and percent deviation measurement. Measurement speed will be reduced because more time will be used to calculate the deviation.

#### **Nominal Value**

Nominal must be set before deviation measurement, because the absolute deviation is the difference between the measured value of the component and a previously stored nominal value.

#### **Absolute deviation measurement**

The difference between the measured value of the device under test and a previously stored nominal value are displayed. The formula used to calculate the deviation is as follows.

$$\Delta = X_x - X_n \quad 2-4$$

Where,  $X_x$ : the measured value of the device under test  
 $X_n$ : the stored nominal value

The unit of the absolute deviation is the same with the value in direct mode, positive or negative deviations are possible.

#### **Percent deviation measurement**

The difference between the measured value of the device under test and a previously stored nominal value are displayed as a percentage of the nominal value. The formula used to calculate the percent deviation is as follows.

$$\Delta \% = \frac{X_x - X_n}{X_n} \times 100\% \quad 2-5$$

Where,  $X_x$ : the measured value of the device under test  
 $X_n$ : the stored nominal value

In percent deviation measurement the measurement value displays in percentage mode with the resolution of 0.01%.

### 2.3.2.3 □ Voltage and Current Measurement

Level setup is to set the level value generated by the signal source. Normally, the actual level across the tested component is always lower than the set value due to the output impedance of the signal source and the impedance of the tested component.

The actual voltage level  $V_x$  across the device under test and the actual current level  $I_x$  through the device under test are given as follows:

$$V_x = \frac{Z_x}{R_i + Z_x} \times V_i \quad I_x = \frac{V_i}{R_i + Z_x} \quad 2-6$$

Where,  $V_i$ : the setup voltage level  
 $Z_x$ : the impedance of the device under test  
 $R_i$ : the output impedance of the signal source

In order to monitor the actual voltage and current level, you can select the V/I display mode. Then window Display A displays the actual voltage level across the device under test with the default unit of V; Window Display B displays the actual current level through the device under test with the default unit of  $\mu A$ .

When measuring the components which are sensitive to the magnitude of signal level, such as inductor with magnetic core and porcelain capacitor etc., this level monitor function is useful to find if they are measured and compared under the same level conditions (refer to Chapter III).

2.3.2.4 □ Display Digits

The maximum number of display digits is five, sometimes is four digits. The table below describes when four digits and five digits are used by the instrument.

Digits for last measurement	First two digits of the measurement value	Digits for this measurement
4 digits	< 59	5 digits
5 digits	> 62	4 digits

Table 2-2 Display Digits and Measurement Value

Table 2-2 shows the relationship between the measurement values and the display digits. The instrument will not change the display digits when the first two digits of the measurement value is in the range of 59 to 62. Thus frequent changes of display digits are avoided when there is a small change of the measurement value.

2.3.3 □ Measurement Level

The default measurement level is effective value 1V, when the instrument is switched ON. TH2817 has three measurement levels for choice: 1V 0.3V 0.1V

An inductor's inductance value may differ widely depending on the current through the inductor due to the permeability of its core material.

Usually, high test level is used for normal test of components (such as capacitor, resistor and some kind of inductor), and low test level is used for those components which work in the circuit of low level (such as semiconductor device, output impedance of battery, inductor and nonlinear impedance component). For some devices, the measurement values differ widely depending on the measurement level, for example inductor components. And the voltage level actually applied across the device may be different with the set value, refer to 2.3.2.3.

2.3.4 □ Measurement Speed

TH2817 provides three measurement speeds: fast, medium and slow.

2.3.4.1 □ Measurement Time

The measurement time consists of two main parts: integration time and calculation time. The sum of integration time and calculation time determined the measurement speed.

- The calculation time is about 30 ms;
- Integration time in fast speed: approx. 20 ms;
- Integration time in medium speed: approx. 160 ms;
- Integration time in slow speed: approx. 650ms;
- So we can calculate the approx. speeds:
- Fast speed: approx. 20 times/sec.
- Medium speed: approx. 5 times/sec.
- Slow speed: approx. 1.5 times/sec.

#### 2.3.4.2 Averaging Rate

The averaging rate can be set in the Second Menu.

We can use the averaging function to acquire the more stable and accurate measurement value, but the measurement speed will be decreased.

The averaging rate of TH2817 can be programmed from 1 to 99. The default value is 1, when the instrument is switched on.

For example averaging rate is 4, the measurement values for each measurement are C1, C2, C3 and C4.

In CONT mode, the instrument outputs the average value  $C_C$  after four measurements. The value  $C_C$  finally displayed by the instrument can be given by

$$C_C = (C_1 + C_2 + C_3 + C_4) / 4$$

In SINGLE mode, the instrument outputs four averaging values ( $C_{S1}$ ,  $C_{S2}$ ,  $C_{S3}$  and  $C_{S4}$ ) after the instrument is triggered once. They can be given as follows.

$$C_{S1} = C_1;$$

$$C_{S2} = (C_1 + C_2) / 2;$$

$$C_{S3} = (C_1 + C_2 + C_3) / 3;$$

$$C_{S4} = (C_1 + C_2 + C_3 + C_4) / 4.$$

#### 2.3.5 Measurement Range

##### 2.3.5.1 Range and the Effective Measuring Range

TH2817 has five ranges: 10Ω, 100Ω, 1 kΩ, 10 kΩ and 100 kΩ. The measurement range is selected according to the impedance of the device under test even if measurement parameter is capacitance or inductance. When measurement range is set to AUTO, the instrument will judge if the optimum measurement range is selected after each measurement. If the range is the optimum range, the instrument calculates and displays the measurement value; otherwise the instrument should adjust the measurement range and measure again. So in AUTO mode, more time will be used to select the optimum measurement range. We usually discuss the measurement speed when the measurement range is set manually.

Table 2-3 tells us how to select the optimum range:

RANG NO.	RANGE	RANGE UP	RANGE DOWN
0	100kΩ	42kΩ ↑	40V ↓
1	10kΩ	4.2kΩ ↑	4kΩ ↓
2	1kΩ	420Ω ↑	400Ω ↓
3	100Ω	42Ω ↑	40Ω ↓
4	10Ω	↑	↓

Table 2-3 How to select the optimum range

From Table 2-3, we can find that there is a given limit to divide two neighboring ranges,

instead a range of impedance is provided. The high limit of the effective measurement range will not be equal the low limit of another range. This is designed to avoid frequent changes when the impedance under test is closed to the limit values. For some components it may be measured in two ranges. For example:  $Z_x = 5.2k\Omega$ , it will be measured in Range 1 or in Range 2.

When  $f > 10$  kHz, only Range 1 to 4 are used, Range 0 is not in use.

According the test frequency, capacitance, or inductance, the range of the capacitor or the inductor can be calculated.

For example:  $C_x = 0.22\mu F$ ,  $D = 0.0010$ , measurement frequency  $f = 10$  kHz, then

$$Z_x = R_x + \frac{1}{j2\pi f C_x}$$

$$|Z_x| \approx \frac{1}{2\pi f C_x} = \frac{1}{2\pi \times 10 \times 10^3 \times 0.22 \times 10^{-6}} = 72.37\Omega$$

From Table 2-3, the optimum range of this capacitor is Range 3.

#### 2.3.5.2 □ Range Hold

When the components to be measured have the same nominal, we can set the range mode to HOLD to increase the measurement speed. When in HOLD mode, the instrument will not spend any time to select the range. The steps to select the optimum range are as follows:

1. Press **□** or **□** keys to select the function of RANGE;
2. Make sure that the range mode is in AUTO state;
3. Connect one of the components to the fixture;
4. Set the range mode to HOLD using **▲** or **▼** keys after the measurement value is stable.

If the impedance of the device under test is out of the effective measuring range of the held range, TH2817's measurement accuracy does not meet its specification. So make sure that the optimum range is selected when using the range hold function.

#### 2.3.6 □ CONT and SINGLE Mode

CONT is the default measurement mode when the instrument is turned on. In this mode, the instrument measures continuously. After last measurement is finished, another measurement begins.

Press **□** or **□** keys to select the function MODE, you can set the SINGLE mode by pressing **▲** or **▼** keys. In SINGLE mode, the instrument makes one measurement only when it is triggered. The instrument can be triggered by **START** key on the front panel, by the signal of the Handler interface or by the instruction via the RS-232C interface.

#### 2.4 □ Functions in the Second Menu

All functions in the second menu are shown as follows in Table 2-4.

No.	Functions		States	
	Name	Display B	Name	Display A

1	Measurement Frequency	F R E - -	100 Hz	0.1000
			120 Hz	0.1201
			1 kHz	<u>1.0000</u>
			10 kHz	10.000
			40 kHz	40.000
			100 kHz	100.00
2	Averaging rate	A V E - -	1 ~ 20	<u>1 - 20</u>
3	Equivalent circuit	E Q U - -	Series	<u>SER</u>
			Parallel	PAR
4	PPM Display of D or Q	P D Q - -	OFF	<u>OFF</u>
			ON	ON
5	Volume	A L A - -	High	<u>Hi</u>
			Low	Lo
			OFF	OFF
6	Alarm Bin	V O L - -	Bin 1	<u>P1</u>
			Bin 2	P2
			Bin 3	P3
			No-Good	NG
7	Auto L, C & R	L C R - -	OFF	<u>OFF</u>
			ON	ON
8	Non-Correction	N C L - -	OFF	<u>OFF</u>
			ON	ON
9	Serial Interface	R S C - -	OFF	<u>OFF</u>
			ON	ON
10	Print Interface	P R N - -	OFF	<u>OFF</u>
			ON	ON
11	Handler Interface	H A N - -	OFF	<u>OFF</u>
			ON	ON
12	Sorting	S O R - -	OFF	<u>OFF</u>
			△%	PER
			△	ABS
			Direct	DIR
13	Correction	C L R - -	Open Correction	<u>OPEN</u>
			Short Correction	SHORT

Table 2-4 Functions in the Second Menu

The Second menu is described in section 2-2. Press **SET** key in the Measurement State, the instrument enters the Second Menu. All underlined and shaded states in the above table are the default states when the instrument is switched on. The following paragraph describes how to set the states of the functions.

After entering the Second Menu, the current function is displayed in the window of Display B and the current state of this function flashes in the window of Display A. You can select the function by pressing the **□** and **□** keys until the function is displayed in the window of Display B.

After the function is selected, you can press **▲** or **▼** keys to select the state, until the required state flashes in the window of Display A. After all functions are set, press **START** key to

return back to the Measurement State, or press **SET** key to enter the Third Menu.

2.4.1 □ Set the Test Frequency

The test signal applied upon the tested component is a pure sine signal generated by the signal source. The frequency and level can be programmed through the front panel or the RS-232C interface. The default frequency and level are 1 kHz and 1Vrms separately when the instrument is switched on. The level control is described in section 2.3.3, and the frequency setup is described as follows:

Different devices are measured under different frequencies, for example electrolytic capacitor is usually measured under the frequencies of 100 Hz or 120 Hz, while metal film capacitor is usually measured under the frequencies of 1 kHz or 10 kHz. The actual frequency is selected according to the measurement requirements.

TH2817 provides six frequencies:  
 100 Hz 120 Hz 1 kHz 10 kHz 40 kHz 100 kHz

The accuracy of frequency is ±0.02%. When you set the frequency, kHz is used as the default unit for the frequency displayed in window of Display A.

2.4.2 □ Equivalent Model

The actual capacitor, resistor and inductor are not the ideal capacitor, resistor and inductor. Normally, a component has the characteristics of the resistor and the reactor at the same time. The actual component is composed of an ideal resistor and reactor (ideal inductor or capacitor) in series or parallel equivalent circuits. The resistor and reactor in both series and parallel models can be measured by TH2817. The values in the two different equivalent circuits can be converted to each other mathematically. The values are different due to the quality factor Q (or the dissipation factor D).

Table 2-5 shows the relations between the series model and the parallel model. For a given frequency, the dissipation factor D and the quality factor Q have the same values in the two equivalent circuits. D and Q have the reciprocal relation.

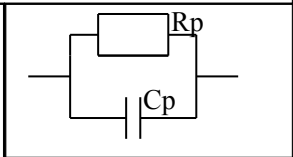
Circuits	D	Relations
C 	$D = \frac{1}{2\pi f C_p R_p} = \frac{1}{Q}$	$C_s = (1 + D^2) C_p$ $R_s = \frac{D^2}{1 + D^2} R_p$

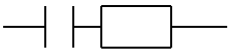

	Cs Rs	$D = 2\pi f R_S C_S = \frac{1}{Q}$	$C_P = \frac{1}{1 + D^2} C_S$ $R_P = \frac{1 + D^2}{D^2} R_S$
L		$D = \frac{2\pi f L_P}{R_P} = \frac{1}{Q}$	$L_S = \frac{1}{1 + D^2} L_P$ $R_S = \frac{D^2}{1 + D^2} R_P$
		$D = \frac{R_S}{2\pi f L_S} = \frac{1}{Q}$	$L_P = (1 + D^2) L_S$ $R_P = \frac{1 + D^2}{D^2} R_S$

Table 2-5 Relations between the series and the parallel circuits

Where: L: Inductor C: Capacitor f: Frequency

R: Resistor D: Dissipation Factor Q: Quality Factor

Subscript s means series model and subscript p means parallel model.

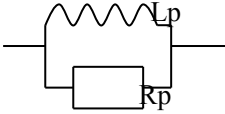
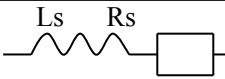
$$D = 1/Q$$

$$X_s = 1/(2\pi f C_s)$$

$$\text{Or } X_s = 2\pi f L_s$$

Form the above table, we can see that the parameters have relations with  $D^2$  or  $Q^2$ , and the value of  $D^2$  will directly affect the values of the parameters. Take the following capacitor as an example:

The capacitance in series model is  $C_s = 0.1\mu\text{F}$ , calculate the capacitance in parallel model for (a)  $D_1 = 0.0100$ , (b)  $D_2 = 0.1000$  and (c)  $D_3 = 1.0000$ .

Solution: According to the formulas in table 2-5, the capacitances in parallel model are:

$$C_{p1} = 0.09999\mu\text{F}$$

$$C_{p2} = 0.09901\mu\text{F}$$

$$C_{p3} = 0.05\mu\text{F}$$

You can find that, when  $D < 0.01$ , the difference between  $C_s$  and  $C_p$  is very small, but while  $D > 0.01$ , the difference will be very obvious. For example, when  $D = 0.1$ , the difference between  $C_s$  and  $C_p$  in percentage is approx. 1%, while  $D = 1$ , the difference in percentage will be approx. 50%.

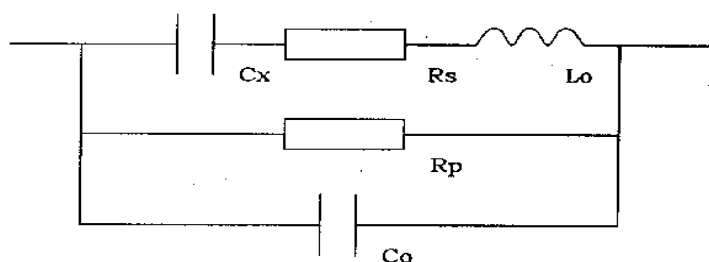

Figure 2-5 The Equivalent Circuit of An Actual Capacitor

Where,

Cx: ideal capacitor

Rx: resistance of the leads

Lo: inductance of the leads

Rp: insulation resistance across the capacitor

Co: stray capacitor across the capacitor.

The following description gives some practical guide lines for selecting the equivalent circuits.

1. Actual equivalent circuit can be selected following the manufacturer's recommendation. If there is no recommendation to be followed, we select the circuit mode according to the variation of D under two different frequencies. If the dissipation factor of a capacitor increases with the increase of the test frequency, series circuit mode will be selected. If the dissipation factor decreases with the increase of the test frequency, parallel circuit should be used. For inductor, the situation is just in the opposite side.

In fact, D is impossible in direct ratio with the test frequency. From figure 2-5, we can find that Rp and Rs exist at the same time. If Rs is more significant than Rp, series mode is selected; If Rp is more significant than Rs, parallel mode is more suitable.

For a given test frequency, Cs and Cp can be calculated according to figure 2-5.

2. You can also make the decision according to the actual application in circuits. If a capacitor is used as a coupling capacitor, series circuit mode is the best choice; if a capacitor is used in a LC oscillator then parallel circuit mode can be selected.

3. Select the equivalent circuits according to the following rules:

Component with low impedance (such as large capacitor and small inductor) is usually measured in series circuit mode;

Component with high impedance (such as small capacitor and large inductor) is usually measured in parallel circuit mode;

Normally, when  $|Z_x| < 10\Omega$ , the series circuit mode is selected;

When  $|Z_x| > 10k\Omega$ , the parallel circuit mode is selected;

When  $10\Omega < |Z_x| < 10k\Omega$ , follow the manufacturer's recommendation.

The default circuit mode is series circuit mode when the instrument is switched on.

#### 2.4.3 □ D, Q Displayed in PPM Mode

In some occasions, PPM mode is used to acquire the high resolution of D and Q.

Note: In order to get a stable measurement value of D or Q in PPM Mode, it is suggested to increase the averaging rate and select the medium or slow measurement speed.

The PPM LED lamp is ON, when sub-parameters D or Q is displayed in PPM mode. In PPM mode the display range is from 0 to 99999 without a decimal point.

#### 2.4.4 □ Volume and State of Alarm

The volume and state of alarm is effective when sorting function is ON.

There are three states for volume of alarm: High state, Low state and Off state. When the

High state is selected in the Second Menu, a high beep will be heard; when the Low state is selected in the Second Menu, a low beep will be heard; when the Off state is selected in the Second Menu, then no beep will be heard.

The state of alarm indicates which bin will be alarmed. P1, P2, P3 and NG can be programmed as the alarm bin.

#### 2.4.5 Automatic Selection of Parameters L, C and Z

We can use the MEAS function to select the parameters to be measured. The measurement parameters can also be selected by the instrument itself, when the function of LCR AUTO is set to ON state. When the function of LCR AUTO is ON, the MEAS function in the front panel will be disabled. The instrument selects the parameters according to the following rules:

When  $Z > 50M\Omega$ , Z/Q will be selected and “OPEN” will be displayed in the window of Display A, which means that the test terminals are opened;

When  $Z < 80m\Omega$ , Z/Q will be selected, and “SHORT” will be displayed in the window of Display A, which means that the test terminals are shorted;

When  $80m\Omega < Z < 50M\Omega$ ,  
 if  $Q < 0.125$ , Z/Q will be selected;  
 if  $Q \geq 0.125$ , L/Q will be selected;  
 if  $Q \leq -0.125$ , C/D will be selected.

Therefore, when LCR AUTO is ON, only three kinds of parameters Z/Q, L/Q and C/D can be selected.

#### 2.4.6 Correction

In order to maintain high measurement accuracy, SHORT and LOAD corrections for correcting the stray admittance, the residual impedance, and the other errors can be performed. OPEN correction and SHORT correction are provided by TH2817.

When TH2817 performs OPEN/SHORT correction, all the frequency points are corrected. When test speed or test level is changed, another OPEN/SHORT correction should be performed. The correction data for last time is rewritten after the correction is finished.

All correction data is stored in a non-volatile memory inside the instrument, so you don't have to correction the instrument again when the instrument is switched on. But if measurement conditions are changed, such as environment temperature, humidity, cable length, another correction is required.

The instrument performs Open and Short corrections for all frequency points and all measurement ranges.

The procedures of Open correction are described in table 2-6, and the procedures of Short correction are described in table 2-7.

No.	Operations	Display A	Display B	Descriptions
1	SET	Current frequency	FRE--	Enter the second menu
2		OPEN	CLEAR	Open the test terminals
3	START	0.10000	OPE-0	Open correction for 100 Hz, range 0
4	--	0.1201	OPE-0	Open correction for 120 Hz, range 0
5		1.0000	OPE-0	Open correction for 1 kHz, range 0

6		10.000	OPE-0	Open correction for 10 kHz, range 0
7		40.000	OPE-0	Open correction for 40 kHz, range 0
8		100.00	OPE-0	Open correction for 100 kHz, range 0
9		0.1000	OPE-(1-4)	Open correction for 100 Hz, range 1 to 4
10		120.01	OPE-(1-4)	Open correction for 120 Hz, range 1 to 4
11		1.0000	OPE-(1-4)	Open correction for 1 kHz, range 1 to 4
12		10.000	OPE-(1-4)	Open correction for 10 kHz, range 1 to 4
13		40.000	OPE-(1-4)	Open correction for 40 kHz, range 1 to 4
14		100.00	OPE-(1-4)	Open correction for 100 kHz, range 1 to 4
15		100.00	OPE-C	Open correction completed
16		*****	*****	Return to the Measurement state automatically

Table 2-6 Procedures of Open correction

No.	Operations	Display A	Display B	Descriptions
1	SET	Current frequency	FRE--	Enter the Second Menu
2	□	OPEN	CLEAR	Open the test terminals□
3	∧ or ∨	SHORT	CLEAR	Short the test terminals
4	START	0.1000	Sho-0	Short correction for 100 Hz, range 0
5		0.1201	Sho-0	Short correction for 120 Hz, range 0
6		1.0000	Sho-0	Short correction for 1kHz, range 0
7		10.000	Sho-0	Short correction for 10kHz ,range 0
8		40.000	Sho-0	Short correction for 40kHz ,range 0
9		100.00	Sho-0	Short correction for 100kHz,range 0
10		0.1000	Sho-(1-4)	Short correction for 100Hz, range 1 to 4
11		0.1201	Sho-(1-4)	Short correction for 120Hz, range 1 to 4
12		1.0000	Sho-(1-4)	Short correction for 1 kHz, range 1 to 4
13		10.000	Sho-(1-4)	Short correction for 10kHz, range 1 to 4
14		40.000	Sho-(1-4)	Short correction for 40kHz, range 1 to 4
15		100.00	Sho-(1-4)	Short correction for 100 kHz, range 1 to 4
16		100.00	Sho-C	completion of clear “0” in open circuit
17		*****	*****	Return to the Measurement state automatically

Table 2-7 Procedures of Short correction

Note: If “FAIL” is displayed in window of Display B during the correction, this means that the Open/Short correction is failed for the current frequency and range. The instrument continues the rest correction without storing the failed data.

Set the no-correction function to ON state in the Second Menu, the measurement values without correction are displayed; Set the no-correction function to OFF state, then the measurement values with correction are displayed again.

In order to make reliable correction, following rules should be observed:

1. Keep the same condition of the measurement terminals with that when the correction is performed;
2. When perform a short correction data measurement, a sample shorting plate should be

used to short the high and low terminals. The shorting bar should have very low residual impedance, so a high conductivity metal plate that is not easily corroded, is recommended.

3. Perform the corrections and measurements under the same conditions for example the same level, speed and frequency.

## 2.5 □ Sorting Function

### 2.5.1 □ Introduction of Sorting

TH2817 can sort the devices under test into four Bins: P1, P2, P3 and NG. NG means no good. NG is effective when either the main parameter or the sub parameter is not within their limits. P1 to P3 are effective when the sub parameter is within the limit of sub parameter and the main parameter is within the limits of P1 to P3.

TH2817 has three kinds of sorting modes, Direct mode (DIR), Absolute deviation mode (ABS) and Percent deviation mode (PER). There is no relations between the sorting mode and the display mode (Direct,  $\Delta$  and  $\Delta\%$ ). For example, measurement value can be displayed in Direct mode and be sorted in Percent deviation mode.

Before sorting the component, set the measurement parameters, level, frequency, speed and equivalent circuit.

Use the sorting function to select a sorting mode in the Second Menu. PER, ABS, DIR and OFF can be selected. Before setting the bin limits and nominal values, a sorting mode must be selected.

The Handler interface works when Handler interface is ON and the instrument is in Single mode. Through Handler interface the instrument can be triggered and the sorting results together with WAIT and EOC signals can be outputted at the same time. For details about the Handler interface, refer to Section 2.6.

### 2.5.2 □ Limits and Nominal Setup

The bin limits and nominal value must be set before sorting is started. Each bin has a pair of limits: the high limit and the low limit. Usually the high limit must be greater than the low one. Different bin limits are set for different sorting modes, direct value for DIR mode, absolute deviation value for ABS mode and percent deviation value for PER mode. When the ABS or PER mode is selected, nominal value is needed. Nominal value and limits in DIR and ABS mode have their units. Bin limits for three modes are stored in their own areas, but only one nominal value is stored.

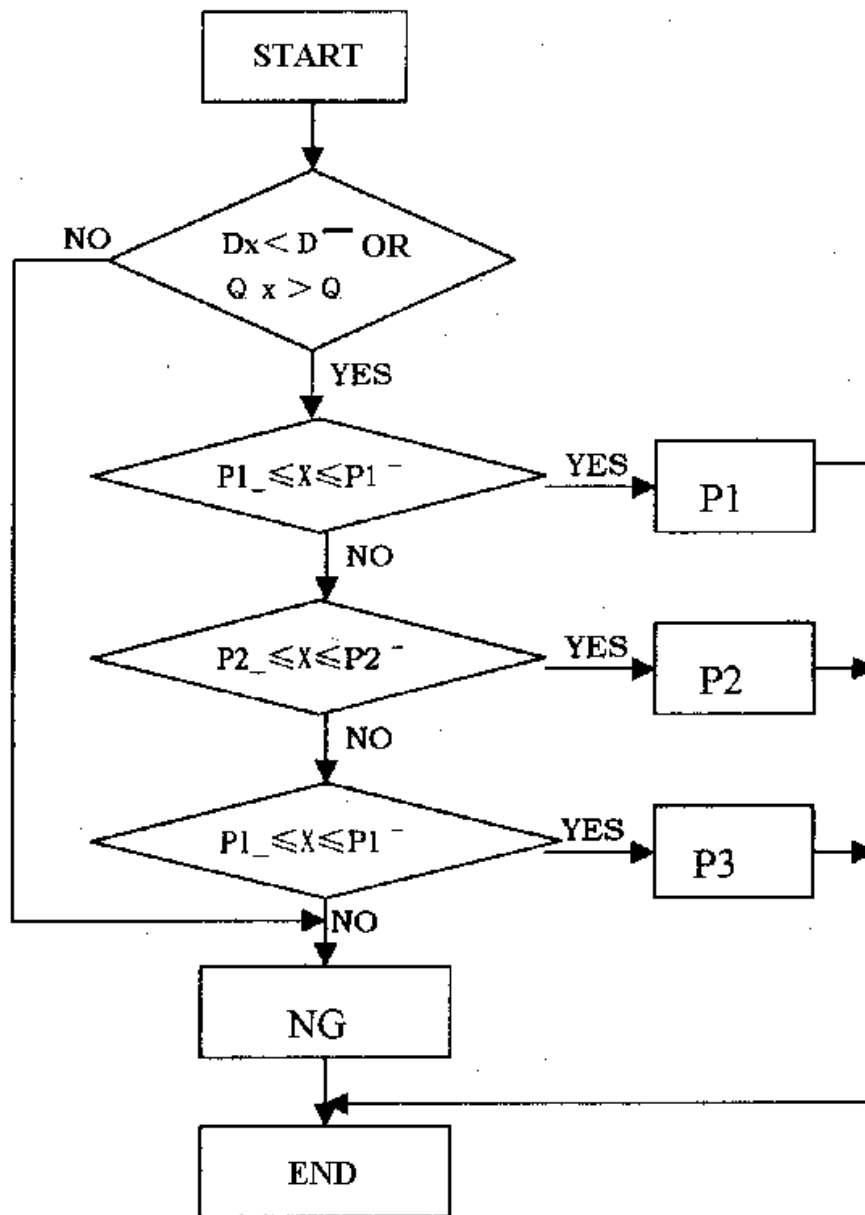

Note: X is the measurement value of main parameter.

Figure 2-6 Flow Chart of Sorting

There are two methods for specifying primary parameter limits. In both methods the high limit must be greater than the low limit for a certain pairs of limits.

**Tolerance Mode:** The tolerance mode specifies bin limits by the deviation from the specified nominal value. There are two methods used to specify the tolerance mode limits, the deviation in percent and by absolute deviation value. (Refer to Figure 2-7.)

The limit values for tolerance mode sorting must be set in the order of the narrower limits to the wider limits. If BIN 1 has the widest limits, all of the devices will be sorted into BIN 1.

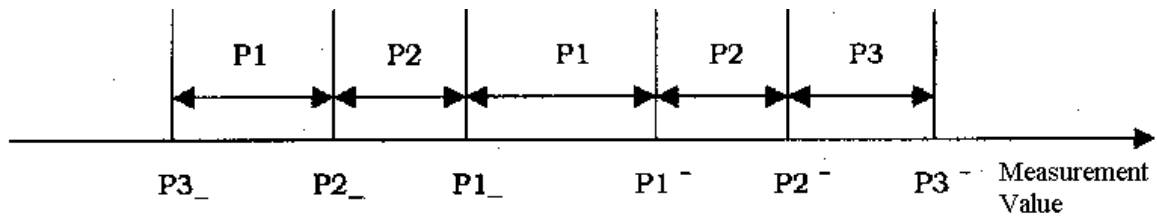

Figure 2-7 Tolerance Mode

**Sequential Mode:** The sequential mode specifies bin limits as the actual measurement value. The limits must be set in order from the smallest value to the largest value. There can be openings and duplications between the bin limits. (Refer to Figure 2-8.)

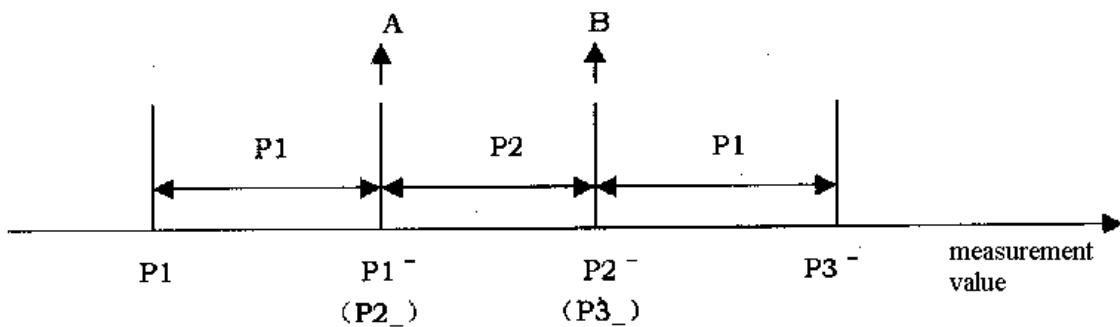

Figure 2-8 Sequential Mode

The nominal value is set according to the selection of measurement parameters. Nominal value is regarded as capacitance for C/D, inductance for L/Q, impedance for both R/Q and Z/Q. The unit of the nominal is indicated in the window of Display A.

The bin limits are set according to the sorting mode.

Percent deviation mode (PER): the limits are deviations in percent without units;

Absolute deviation mode (ABS): the limits are absolute deviations from the nominal value;

Direct mode (DIR): the limits are direct parameter values, nominal value has no meaning in this mode.

When sorting state is set to OFF, the bin limits can also be set in the default Percent deviation sorting mode.

There are three steps to complete the setting of sorting:

1. Select the measurement parameters in the First Menu (or in the measurement state);
2. Select the sorting mode in the Second Menu;
3. Set the limit values and nominal value in the Third Menu.

Four keys  $\square$ ,  $\square$ ,  $\wedge$  and  $\vee$  are used to set the limit and nominal values in the Third Menu. Use  $\square$ ,  $\square$  keys to select the item to be changed, the item may be a digit, a decimal point, a unit or symbol of a bin limit. The item flashes when it is selected; Use  $\wedge$  and  $\vee$  keys to change the

value or state of the flashing item.

The states of the four kinds of flashing items are given as follows:

A. The symbols of bin limits and nominal:

No.	Symbol	Description	Down	Up
1	P1--	High limit of bin P1	↓	↑
2	P1.--	Low limit of bin P1		
3	P2--	High limit of bin P2		
4	P2.--	Low limit of bin P2		
5	P3--	High limit of bin P3		
6	P3.--	Low limit of bin P3		
7	D--	High limit of D		
8	Q--	Low limit of Q		
9	STD--	Nominal value		

B. Units. (But D, Q and limits in percent have no unit.)

No.	C	L	R & Z	Down	Up
1	pF	μH	Ω	↓	↑
2	nF	mH	kΩ		
3	μF	HΩ	MΩ		

C. Decimal Points.

No.	Position of Decimal Point	Down	Up
1	After the 5th digit	↓	↑
2	After the 4th digit		
3	After the 3rd digit		
4	After the 2nd digit		
5	After the 1st digit		

D. Digits of the value.

Numbers of 0 to 9 can be selected for the digits from the 2nd digit to the 5th digit by pressing  $\wedge$  and  $\vee$  keys, and numbers of 0 to 9 plus the negative symbol “-” can be selected for the first digit.

Use  $\square$  and  $\square$  keys to switch between the four kinds of flashing items, as follows:

No.	Flashing item	Left	Right
1	Symbol of parameter	↓	↑
2	Unit		
3	Decimal Point		
4	Digits		

### 2.5.3 Example of Sorting

Comparison function can be set ON in both continuous and single modes. In order to sort correctly, measurement parameters, comparison limits and nominal should be set before the comparator begins to work.

In single mode, you can use Handler interface to send out the sorting results, and receive external “START” trigger signal.

The sorting parameters and states are given as follows:

Measurement parameter: C/D      Sorting Mode: ABS

P1 = 2.5nF                              P1. = -1.5nF

P2 = 4.5nF                              P2. = 2.5nF

P3 = -1.5nF                             P3. = -5.5nF

D = 0.0035

STD = 100nF

No.	State	Function	Keys	Display A	Display B
1	Measurement	Select C/D	∧, ∨, □, ▢	XXXXX	XXXXX
2	2nd Menu	Enter the 2nd Menu	SET	XXXXX	FRE--
3	2nd Menu	Select sorting function	□, ▢	OFF	SOR--
4	2nd Menu	Select sorting mode	∧, ∨	ABS	SOR--
5	2nd Menu	Enter the 3rd Menu	SET	00000. pF	P1--
6	2nd Menu	Select the unit item	□	00000. pF	P1--
7	2nd Menu	Set the unit of P1	∧, ∨	00000. nF	P1--
8	2nd Menu	Select the decimal item	□	00000. nF	P1--
9	2nd Menu	Set the decimal point	∧, ∨	0000.0 nF	P1--
10	2nd Menu	Select the 5th digit	□	0000.0 nF	P1--
11	2nd Menu	Set the 5th digit	∧, ∨	0000.5 nF	P1--
12	2nd Menu	Select the 4th digit	□	0000.5 nF	P1--
13	2nd Menu	Set the 4th digit	∧, ∨	0002.5 nF	P1--
14	2nd Menu	Select the limit symbol	□, ▢	0002.5 nF	P1--
15	2nd Menu	Select P1--	∧, ∨	00000. pF	P1--
Repeat steps from 6 to 15 to set P1., P2., P2., P3., P3., D and STD separately					
XX	Measurement	Return to the measurement state	START	XXXXX	XXXXX

Note: Those shaded parts in the above table are the flashing items in the window of Display A or B.

### 2.6 Handler Interface

By using the handler interface, TH2817 can easily be combined with a component handler, and a system controller to fully automate component testing, sorting, and quality control data processing. External “START” signal is received for triggering the instrument to start measurement, while WAIT and EOC signals are output. WAIT means that the instrument is busy with measurement and calculation, and EOC means the end of A/D conversion. When EOC is effective, the component handler may move to the next position to prepare for another

measurement, but the component handler must keep still before EOC is effective. Sorting result of each bin is outputted by an open-collector gate.

Handler interface locates on the rear panel of the instrument.

#### 2.6.1 □ Operation

The Handler interface works only when the following three conditions are met:

1. The measurement mode is set to SINGLE mode;
2. One of “PER”, “ABS” or “DIR” should be selected as the sorting mode;
3. Set Handler interface to ON state in the Second Menu.

Following signals are provided by the Handler interface:

1. **START**: Input trigger to start a measurement. Opto-isolated and open collector with internal pull-up resistor to +5V. The minimum required pulse width is > 2.5ms.
2. **WAIT**: An opto-isolated signal outputted by the Handler interface. This signal tells the Handler that the instrument is busy performing a measurement, comparison, or calculation.
3. **EOC**: An opto-isolated signal outputted by the Handler interface to tell the Handler when the end of conversion occurs. At the end of conversion the instrument enters the correction, calculation and comparison phase and the handler is free to position the next component for measurement.
4. **Bin Sorting results** (P1, P2, P3 and NG): Opto-isolated and open collector output signals are used to indicate the pass/fail judgment for each bin.
5. **Common**: The Common Ground for isolated signals is not connected with the instrument Ground.

Figure 2-9 shows the timing diagram of the Handler interface.

A, B and C are the three component measured. Component A is sorted to Bin P1, B is sorted to P1 and C is sorted to P2.

**T1**: T1 is the pulse width of START which must be > 2.5ms. When START goes high, the instrument starts a measurement. START signal should return low before the WAIT signal goes low; otherwise the next START signal will not be effective. If there is no external “START” signal, the **START** key on the front panel can also be used.

**T2**: During the time of T2 the instrument performs A/D conversion, correction, calculation, and comparison. The value of T2 depends on the measurement speed. At the end of T2, the comparison results are outputted to the component handler.

**T3**: This is the period when last measurement is finished and the next measurement has not been started. The handler is free to position the next component for measurement.

**T4**: Instrument performs A/D conversion during the time of T4.

The comparison output signals are effective until the signals are outputted the next time, as shown in Figure 2-9.

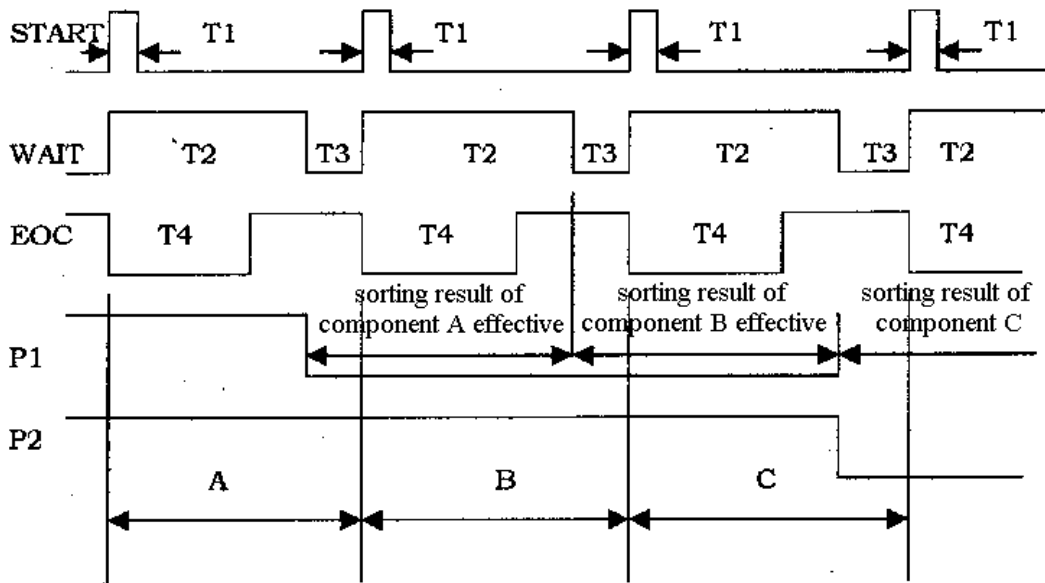

Figure 2-9 Timing Diagram For The Handler Interface

2.6.2 Connector of HANDLER Interface

Handler interface connector has 9 pins as follows:

Pin No.	Function
1	NG
2	P1
3	P2
4	P3
5	WAIT
6	EOC
7	START
8	NC
9	Common

}

opti-  
isolated and  
open  
collector



Table 2-8 HANDLER Interface Pin Assignments

2.7 Standard Printer Interface

TH2817 provides a standard parallel printer interface which can be connected to any printer which has the standard printer interface. Function setup, comparison limits, measurement value, and comparison results can be printed.

2.7.1 Introduction of Printer Interface

Connect the printer to the printer interface on the rear panel of the instrument. Set the print function to ON state in the Second Menu. Press the **START** key on the front panel to begin printing.

Printer interface connector pin assignments are as follows:

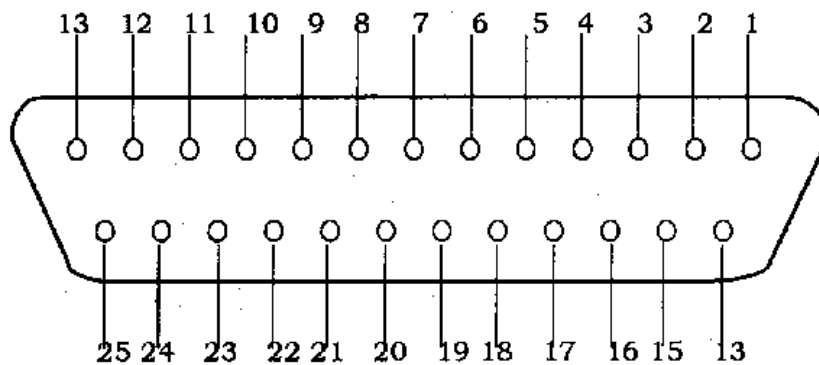

Figure 2-11 Pin Assignments of Printer Interface

Pin assignments for printer interface:

Pin No.	Name	Direction	Function
1	STROBE	Output	The signal tells the printer that data on the bus is effective and ready to be read.
2-9	D0-D7	Output	Data bus. Print data is transmitted through the bus in ASCII code.
10	NC		No connection
11	BUSY	Input	Signal BUSY tells the instrument that the printer is busy and can't receive the data sent by the instrument.
12-13	NC		No connection
14	GND		Instrument logic ground
15	ERROR	Input	Printer error signal. The signal tells the instrument printer is offline or paper out.
16-21	GND		Instrument logic Ground
22-25	NC		No connection

### 2.7.2 Print Format

Set the print function to ON state in the Second Menu. The instrument sends out print information when **START** key is pressed.

In SINGLE mode, the instrument measures and prints after **STATR** key is pressed.

In CONTINUOUS mode, the instrument continuously repeats measurements without printing the measurement results. When **STATR** key is pressed, the next measurement results will be printed out.

If the printer is offline or paper out, "PRINT ERROR" will be displayed in the display windows. After the error is eliminated, measurement results will be displayed in stead of the error information and the print data will be sent out.

State information will be printed for the first time or after any of the states is changed. The states printed are as follows:

1. Measurement parameter (PARAM.);
2. Measurement frequency (FREQU.);



measurement results at the same time.

Accurately the ON/OFF state of serial interface determines whether the instrument can send out measurement results.

TH2817's serial interface meets the RS-232 standard. The serial interface adopts asynchronous serial communication bus with fixed baud rate of 9600 bps, the logic level is  $\pm 8V$  and the maximum transmission distance is 15m. The data format is as follows:

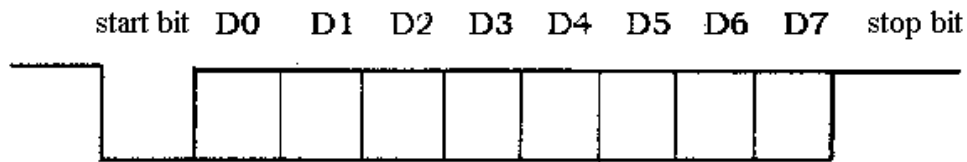

Figure 2-12 Data Format

Only three signal wires are used in serial communication, TXD, RXD and GND. A 9-pin standard connector is used, as shown in Figure 2-13.

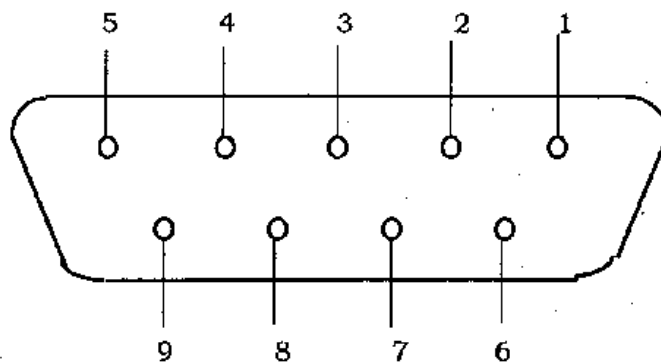

Figure 2-13 Connector of Series Interface

Pin 2: TXD sending terminal

Pin 3: RXD, receiving terminal

Pin 5: GND, instrument ground

Information transmitted through RS-232 Interface is ASCII code.

The output information is listed in Table 2-10 (TH2817 computer)

No.	Function	Symbols	Description
1-2	Start characters	02H, 0DH	Start of information transmitted
3	Main parameter	L, C, R, Z	L: inductance C: capacitance R: resistance Z: impedance
4	Sub parameter	D, Q	D: dissipation factor Q: quality factor
5	Display mode	D, A, P, V	D: direct A: absolute deviation P: percent deviation V: V/I display
6	Level	L, M, H	L: 0.1V M: 0.3V H: 0.1V
7	Test speed	S, M, F	S: slow M: medium F: fast

8	Range mode	A, H	A: auto H: hold (manual)
9	Measurement mode	C, S	C: continuous S: single
10	No-correction	Y, N	Y: measurement value without correction N: measurement value with correction
11	Printer interface	Y, N	Y: printer interface ON N: printer interface OFF
12	Handler interface	Y, N	Y: Handler interface ON N: Handler interface OFF
13	Sorting mode	N, P, A, D	N: OFF P: Percent deviation A: Absolute deviation D: Direct
14	Frequency	1, 2, 3, 4, 5,6	1: 100 Hz 2. 120.12 Hz 3. 1 kHz 4. 10 kHz 5. 40 kHz 6. 100 kHz
15-16	Averaging rate	01-99	Averaging rate from 1 to 99
17	Equivalent circuit	S, P	S: series model P: parallel model
18	PPM mode	Y, N	Y: D, Q displayed in PPM mode N: D, Q displayed normally
19	Volume	N, L, H	N: OFF L: low volume H: high volume
20	Alarm State	0, 1, 2, 3	0: NG 1: P1 2: P2 3: P3
21	Auto LCR	Y, N	Y: LCR auto N: LCR manual
22-27	value of main Parameter	0, 1, 2, 3, 4, 5, 6, 7, 8, 9, -; 20H, 20H, OPEN; 20H, SHORT	0123456789-: measurement value of main parameter 20H, 20H, OPEN: when LCR is AUTO, test terminals opened. 20H, SHORT: when LCR is AUTO, test terminals are shorted.
28-29	Unit of main parameter	20H, $\Omega$ , k $\Omega$ , M $\Omega$ , pF, nF, $\mu$ F, $\mu$ H, mH, H, 20H, V	20H, $\Omega$ : $\Omega$ 20H, V: V
30-35	Sub-Parameter Display	0, 1, 2, 3, 4, 5, 6, 7, 8, 9, -, 20H, 20H, 20H, 20H, 20H, 20H	0123456789-: measurement result of sub parameter 20H, 20H, 20H, 20H, 20H, 20H: when LCR is AUTO, test terminals are shorted or opened six spaces are outputted for sub parameter
36-37	Unit of Sub	D, Q	D: dissipation factor

	Parameter		Q: quality factor
38-40	PPM Indication	PPM, 20H, 20H. 20H	PPM: D, Q displayed in PPM mode 20H, 20H, 20H: D, Q displayed normally
41-42	Sorting Result	20H 20H, NG, P1, P2, P3	20H, 20H: sorting OFF NG: bin of NG P1: bin of P1 P2: bin of P2 P3: bin of P3
41	End character	3FH	The end of output information

Note: 20H is the hexadecimal value of ASCII character space.

Table 2-10: Format of Output Information

Commands for serial interface are shown as in Table 2-11(computer →TH2817)

In the following table, each command can only be sent alone, and you are not allowed to send more than two commands at a time. Each command starts with 02H and 0DH and ends with 3FH.

No.	Command	Length	Description
1	M0	2	Measurement parameters: L/Q
2	M1	2	Measurement parameters: C/D
3	M2	2	Measurement parameters: R/Q
4	M3	2	Measurement parameters: Z/Q
5	M4	2	Measurement parameters: Z/D
6	D0	2	Display mode of direct
7	D1	2	Display mode of $\Delta\%$
8	D2	2	Display mode of $\Delta$
9	D3	2	Display mode of V/I
10	V0	2	Measurement level: 1.0V
11	V1	2	Measurement level: 0.3V
12	V2	2	Measurement level: 0.1V
13	S0	2	Test speed: fast speed
14	S1	2	Test speed: medium speed
15	S2	2	Test speed: slow speed
16	K0	2	Range mode: auto
17	K1	2	Range style: hold
18	F0	2	Measurement frequency: 100Hz
19	F1	2	Measurement frequency: 120Hz
20	F2	2	Measurement frequency: 1kHz
21	F3	2	Measurement frequency: 10kHz
22	F4	2	Measurement frequency: 40kHz
23	F5	2	Measurement frequency: 100kHz
24	E0	2	Equivalent circuit: series
25	E1	2	Equivalent circuit: is parallel
26	W0	2	PPM mode: ON
27	W1	2	PPM mode: OFF
28	U0	2	Volume: off
29	U1	2	Volume: low

30	U2	2	Volume: high			
31	X0	2	Alarm bin: NG			
32	X1	2	Alarm bin: P1			
33	X2	2	Alarm bin: P2			
34	X3	2	Alarm bin: P3			
35	B0	2	Auto LCR: ON			
36	B1	2	Auto LCR: OFF			
37	C0	2	No-correction: ON			
38	C1	2	No-correction: OFF			
39	R0	2	Serial interface: ON			
40	R1	2	Serial interface: OFF			
41	T0	2	Printer interface: ON			
42	T1	2	Printer interface: OFF			
43	P0	2	Handler interface: ON			
44	P1	2	Handler interface: OFF			
45	G0	2	Sorting: OFF			
46	G1	2	Sorting: percent deviation			
47	G2	2	Sorting: absolute deviation			
48	G3	2	Sorting: direct			
49	Z0	2	Open correction			
50	Z1	2	Short correction			
51	AXX	3	Averaging rate: 1-99 X: 0-9 in ASCII character (30H-39H)			
52	N=XXXXXU	8	N is the nominal value X: 0-9 in ASCII character (30H-39H) The digit followed with a decimal point should be added with 80H. For example, the digit 8 followed with a decimal point, then its ASCII value should be 38H+80H=B8H. U is the unit of nominal as follows:			
			U	C	L	Z, R
			31H	pF	$\mu$ H	$\Omega$
			32H	nF	mH	k $\Omega$
33H	$\mu$ F	H	M $\Omega$			
53	HX=XXXXXU	9	H is the high bin limit. The X after H is the bin number (0, 1, 2, 3). H0 is the high limit of D. The value of the high limit is the same with nominal value. When the high limit is a percent rate, U is 20H			
54	LX=XXXXXU	9	L is the low bin limit. The X after L is the bin number (0, 1, 2, 3). L0 is the low limit of Q. The value of the low limit is the same with nominal value. When the low limit is a percent rate, U is 20H			

Table 2-11 Commands of Serial Interface

### 2.9 □ Save the Parameters

Th2817 has a non-volatile memory which saves the parameters without power supply. Here are the parameters saved:

1. Open and Short correction data;
2. Nominal value;
3. Limits in percent deviation sorting mode;
4. Limits in absolute deviation sorting mode;
5. Limits in direct sorting mode;
6. Calibration data of measurement accuracy.

All parameters are stored in the EEPROM without power supply. They will not be lost while you turn off the power of the instrument. If the parameters are stored in a RAM with the power supply of a battery, the parameters stored may be lost due to the failure of battery.

## 3 □ Chapter □ Measurement Basics and Troubleshooting

### 3.1 □ Unpacking and Measurement

#### 3.1.1 □ Attention

1. After unpacking, inspect the contents according to the packing list.
2. Before operating the instrument, read the manual carefully, or make operation under the direction of the person who is familiar with the instrument.

3. Power

The instrument adopts the power supply of 220VAC±10% /50Hz±5%. Before switching on the power supply, make sure that line voltage is correct. Neutral, Line and Earth should be connected correctly as shown in Figure 3-1:

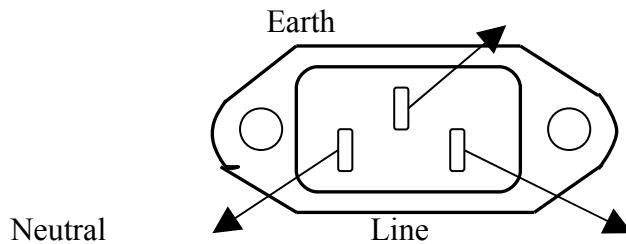

Figure 3-1 Power Supply Receptacle

For protection from electrical shock, the power cable ground must not be defeated. The power plug must be plugged into an outlet that provides a protective earth ground connection.

Then outlet can't be shared with those devices consuming large power to avoid interference or damage of the instrument.

4. The instrument should be operated under the environment conditions specified in the manual. Always keep the instrument and the test terminals away from electrical and magnetic field to avoid influence of the measurement accuracy.

5. Turn off the power supply and draw out the plug, when instrument is not in use, or when covers need to be removed for troubleshooting.

6. Allow the instrument to warm up a minimum of 10 minutes before starting any of the performance tests.

### 3.1.2 Measurement Basics

1. Turn on the instrument with proper power supply, “**TONGHUI TH2817**” will be displayed and shifted in the windows of Display A and B, then the instrument performs the power-on self tests and corresponding information is displayed at the same time, the sequence number is from 99999 to 11111. The instrument will stop self tests when trouble occurs, you can determine what kind of error occurs from the sequence number displayed. Press any key to continue the self tests. For details, refer to section 3.4.1.

2. The states of instrument will be initialized after self tests as follows:

A. The First Menu (or “measurement” state)

Parameter	C/D
Display	Direct
Level	1.0V
Speed	Slow

Range	Auto
Mode	Continuous

B: The Second Menu

Frequency	1kHz
Averaging Rate	1
Equivalent circuit	Series
D,Q PPM Mode	OFF
Sorting	OFF
LCR Auto	OFF
No-correction	OFF
Handler Interface	OFF
Printer Interface	OFF
Serial Interface	OFF
Volume	High
Alarm Bin	P1

3. Select measurement parameters: L/Q, C/D, R/Q, Z/Q or Z/D.
4. If necessary, select suitable equivalent circuit. When Q or D is close to 1, the measurement values in different circuits have a great difference. Refer to section 2.4.2.
5. Select the required frequency from six frequencies provided.
6. Set the measurement level.
7. Select the proper fixture or test cable. Test fixture TH26005 and four-wire Kelvin test cable TH26011 are provided along with the instrument. TH26009 is optional for SMD component.
8. Perform a short correction, using a shorting bar to short between the high terminal and the low terminal.
9. Perform an open correction when nothing is connected to the test terminals.
10. Connect the component to the test terminals and the measurement values are displayed in the windows of Display A and B.

Note 1: If you want to know the actual voltage level across the component and the actual current level through the component, please select the “V/I” display mode.

Note 2: About the precision measurement of small dissipation factor.

In theory, value of D should be always positive. But negative D may be displayed when the dissipation factor is very small (within deviation range of the instrument). If  $D = -0.0001$ , you can adopt the following method.

Select a device which dissipation factor is known and impedance is close to that of the device under test. The selected device also has a very small dissipation factor, then the dissipation factor of the device under test can be given by

$$D_x = D_2 - (D_1 - D_s)$$

Where

$D_x$  is the actual value of the device under test;

$D_2$  is the measurement value of the device under test;

$D_1$  is the measurement value of the reference device;

$D_s$  is the actual value of the reference device;

### 3.2 Measurement of Inductor and Transformer

#### 3.2.1 Measurement of Inductor

The real inductor consists of a winding and a magnetic core, and its characteristics differ with the different magnetic material used. To make an inductor, air is the simplest magnetic material. However inductance is in direct proportion with the magnetic conductivity of the core, air is unsuitable to make inductor due to its tiny magnetic conductivity and the ratio between volume and efficiency. Ferrite and high conductivity magnetic alloy are commonly used as magnetic materials.

The inductance of most inductors will have great changes under different measurement frequency and level. The inductance is affected by the magnetic conductivity  $\mu$  of magnetic materials. The magnetic induction intensity of the magnetic core varies with magnetic field intensity, which is induced by the current flow through the inductor, and the B-H relationship is described by the magnetic curve. Following Figure 3-2 is a typical magnetic curve of an inductor.

When a static magnetic field is applied to the magnetic material, its magnetic induction intensity increases with the increase of the magnetic field intensity (the magnitude of current flow through). Inductance  $L \propto$  magnetic conductivity  $\mu$ ,  $B = \mu H$ , following Figure 3-3 describes the relationship of B, H and L.

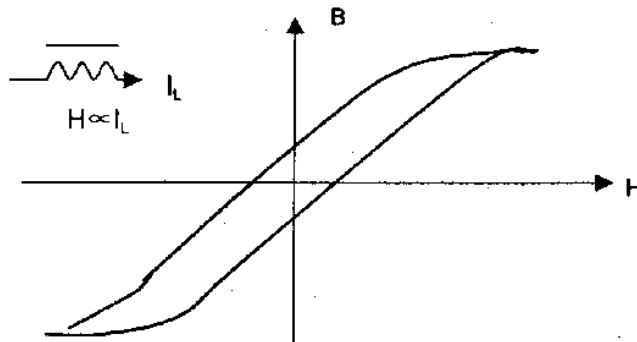

Figure 3-2 Magnetic Curve of Inductor with Magnetic Core

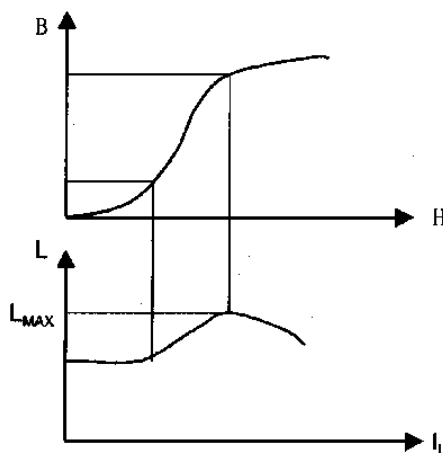

Figure 3-3 Magnetic Field Intensity and Inductance

At first the inductance is small and increases slowly when the inductor is working with a small current. The inductance then increases with the increase of the current flow through the inductor. When the magnetic core of the inductor reaches the saturation point, the inductance then decreases with the increase of current. On the other hand, the dissipation of the magnetic core will increase obviously in high frequency area. This is mainly up to the material and structure of the magnetic core.

To sum up, the measurement value of the inductor varies greatly with different level and frequency.

Different measurement values may be obtained using different instruments, because the current levels are always different for different instruments. This is mainly up to the different voltage levels and output impedances.

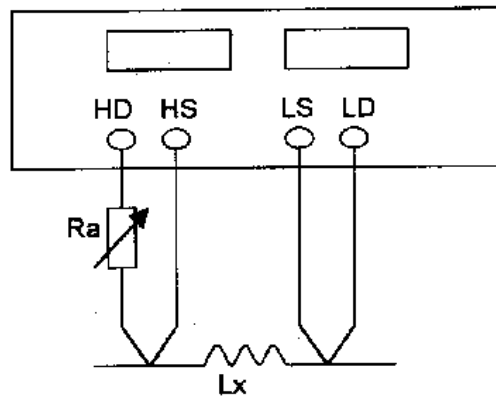

Figure 3-4 Adjustment of output impedance

TH2817 provides three kinds of test level: 0.1V, 0.3V and 1.0V, and the output impedance is about 15Ω for measurement range 0~40Ω. Adopt the above method shown in Figure 3-4, user can adjust the output impedance to acquire the same current level. Thus different instruments may have the same measurement value for a given inductor. Select the display mode “V/I”, you can monitor the actual current level through the inductor when adjusting the resistor Ra. Replace Ra with a fixed resistor after adjustment is finished. By this way, you can solve the problem.

When a high voltage level is applied upon an inductor, the instrument sometimes can not provide the accurate measurement value at some particular frequencies. This is due to nonlinearity of magnetic material which causes distortion of test signal. In order to reduce the effect of nonlinear material, test level should be reduced.

#### Application of Test Fixture

When metal material is closing to the inductor, the leak magnetic flux from the inductor may induce vortex flow inside the metal material. The magnitude of vortex flow is up to the size and shape of the test fixture and the vortex flow in turn influences the measurement value. So test component should be kept as far as possible away from metal materials.

#### Accuracy of Q

Normally, accuracy of Q is not ideal when measured with LCR instrument, especially when Q is high. Q can be calculated by  $Q = X/R = 1/D$ . If  $Q = 100$ , R takes small portion in the impedance of the component, then with a small change of R, Q will change greatly. For example, if R changes 0.1%, namely, D changes 0.001%, then Q will change from 91 to 111.

#### 3.2.2 Measurement of Transformer

TH2817 is not specially designed for transformer measurement; however some main parameters of transformer can be measured using the following methods. Transformer can be looked as a kind of special inductor, and following figure describes the equivalent circuit of transformer.

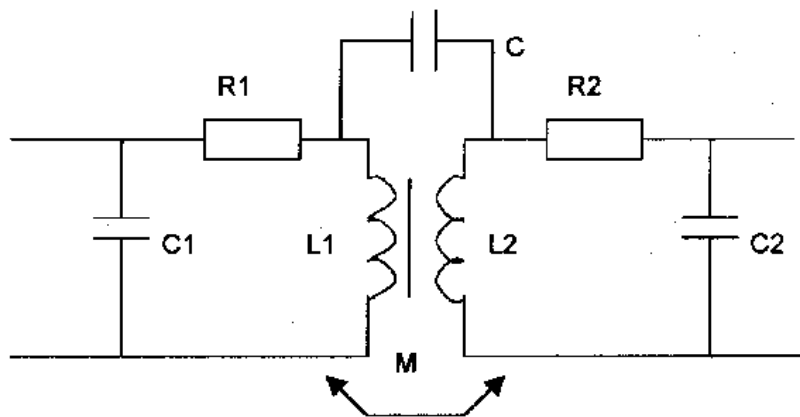

Figure 3-5 Equivalent Circuit of Transformer

In above figure,

L1: primary inductor

L2: secondary inductor

R1: primary magnetic loss and copper loss

R2: secondary magnetic loss and copper loss

C1: primary capacitor

C2: secondary capacitor

M: mutual inductance between primary and secondary inductors

C: Capacitor between primary and secondary inductor

The Primary and Secondary Inductors can be measured as shown in Figure 3-6. Primary inductance (L1) and secondary inductance (L2) can be directly measured. Other windings should be in open state, when one of the inductors is measured, the measured value is affected by capacitor C.

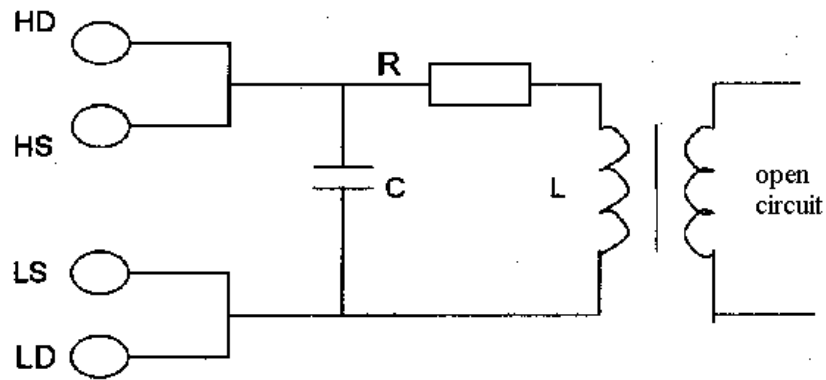

Figure 3-6 Measurement of the Primary or Secondary Inductor

Measurement of Leak Inductance. This measurement value will be the leak inductance when the primary inductor is measured with the secondary inductor shorted. See Figure 3-7.

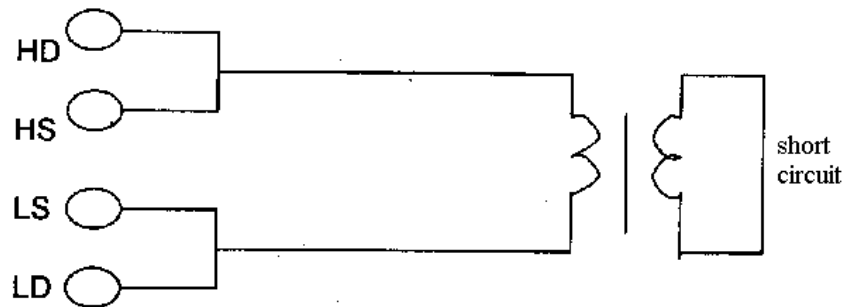

Figure 3-7 Measurement of Leak Inductance

The Capacitor between Primary and Secondary windings can be measured according to Figure 3-8.

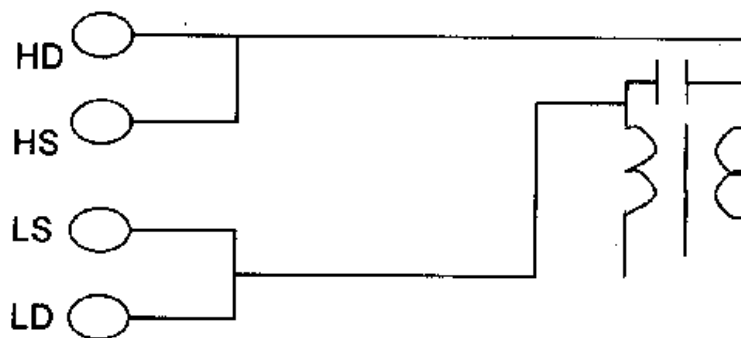

Figure 3-8 Capacitor between Primary and Secondary Windings

Mutual Inductance can be measured by connecting the transformer as shown in Figure 3-9.

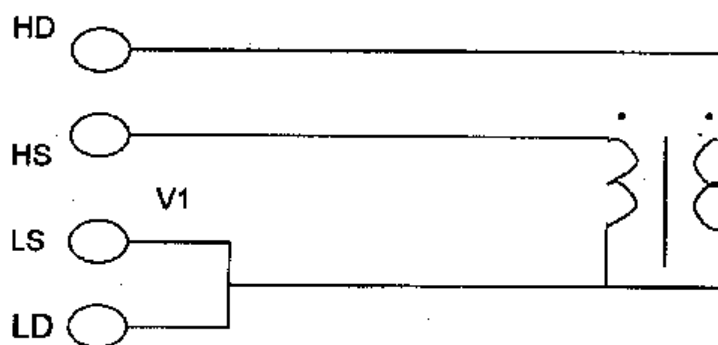

Figure 3-9 Measurement of Mutual Inductance

Measurement of Ratio of Windings. TH2817 cannot measure the ratio directly. It can be measured by two steps. Set the display mode to “V/I” to monitor the voltage and current values. First, measure the voltage of primary winding according to Figure 3-6, write down the voltage  $V_1$  from the Display A, then keep HD and LD unchanged and connect HS and LS to the secondary winding, see Figure 3-10. Write down the voltage  $V_2$  from the Display A, then you can calculate the ratio of windings:  $N = V_1/V_2$ .

If  $V_1$  is close to  $V_2$ , you can use any of the test levels. When  $V_1 > V_2$ , 1V level is recommended and when  $V_1 < V_2$ , level 0.1V is recommended.

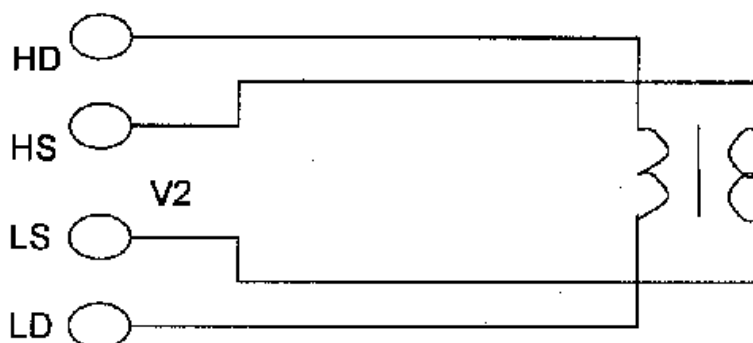

Figure 3-10 Measurement of Secondary Voltage

### 3.3 □ Connection of Component

#### 3.3.1 □ Measurement of Capacitor

Do not apply DC voltage or current to the test terminals. Doing so will damage the instrument. Before you measure a capacitor, be sure the capacitor is fully discharged.

#### 3.3.2 □ Connect the Component

TH2817 has four test terminals and the outer shields of each terminal are connected with the instrument ground, the outer shield can be looked as the fifth terminal. Descriptions of the five terminals are as follows:

- HD: high drive terminal of current;
- LD: low drive terminal of current;
- HS: high sense terminal of voltage;
- LS: low sense terminal of voltage;

⊥: Ground.

The ground shields are used reduce influence of stray capacitance and electromagnetic disturbance. HD, HS and LD, LS should be connected at the lead of the component under test in order to reduce the influence of cable resistance and contact resistance especially in D measurement. When measuring low impedance, the drive terminals and sense terminals should be connected to leads of component separately so as to avoid the influence of lead resistance.

In other words, HD, HS and LD, LS cannot be connected before connecting to the component otherwise measurement error will be caused.

If contact resistance and leads resistance  $R_{lead}$  are far less than the impedance tested (for example  $R_{lead} < Z_x/1000$ , and the accuracy required is 0.1%), then HD, HS and LD, LS can be connected together before connecting to the component under test (two-terminal measurement).

Test fixture is recommended when high accuracy is required. Kelvin test cables have better performance when measurement frequency is less than 10 kHz but it can hardly meet the accuracy requirement when frequency is larger than 10 kHz, because different positions of test leads will directly influence the stray capacitance and inductance between the test terminals.

Therefore, test fixture is recommended for high frequency measurement. If the test cable must be used, try you best not to move the cable during the corrections and measurements.

### 3.3.3 □ Eliminate the Influence of Stray Impedance

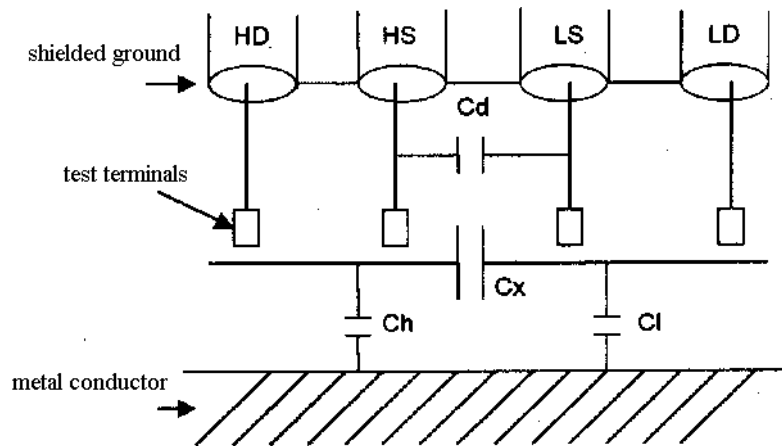

Figure 3-11 Stray Capacitance to ground

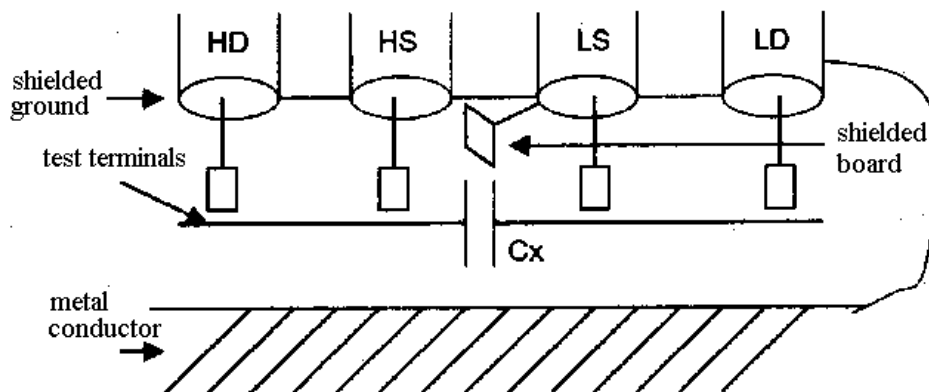

Figure 3-

Method to Eliminate Influence of Stray Capacitance

When component of high impedance (for example small capacitor) is measured, the influence of stray capacitance cannot be ignored. As shown in Figure 3-11, Cd is in parallel with Cx. When there is conductor board under the tested component, capacitance Ch is connected in series with Cl, then Ch and Cl are connected to with Cx in parallel. Cd, Ch and Cl will cause errors to measurement values. To place a grounded conductor between the high terminal and the lower terminal can reduce capacitor Cd. In addition, if the conductor board is grounded, Ch and Cl will be eliminated.

When low impedance component (for example small inductor or large capacitor) is measured, a larger current will flow through the test wires HD and LD. Electromagnetic coupling between the test wires will become the main source of error. Normally, the contact resistance will affect resistance part of the component while the electromagnetic coupling will affect reactance part of the component under test. The best way to eliminate the electromagnetic coupling is to adopt the four-terminal pair connection. But this instrument adopts the four-terminal connection in stead of the four-terminal pair connection. A double-twisted test cable is also helpful to eliminate electromagnetic coupling, because the currents flow through HD and LD have the same magnitude but opposite directions, the magnetic fields induced by HD and LD cancel each other so no external magnetic fields are generated around the cable. There are two methods to make a double-twisted cable. The first method is that HD is twisted with LD and HS is twisted with LS. The other method is to twist the four wires directly. The first method is recommended.

### 3.3.4 □ DC Bias

DC bias function is not provided by TH2817. Some components should be tested with DC bias voltage or DC bias current. For example, the electrolytic capacitor always needs to be measured with DC bias voltage while the inductor always to be measured with DC bias current. Here we introduce the way to measure the component with external DC bias.

#### Measurement with DC Bias Voltage

TH2817 can be applied with an external DC bias voltage of 100V in maximum. DC bias voltage can be applied according to the circuit described in Figure 3-13. Perform open and short corrections when DC bias voltage is 0V to eliminate the influence of the external circuit, then you can measure the component with the DC bias voltage.

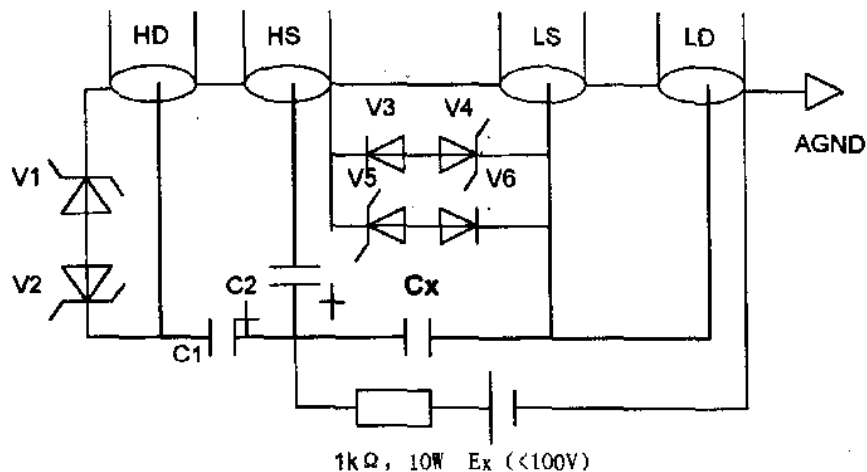

Figure 3-13 Circuit for External DC Bias Voltage

- Where,
- Cx: the capacitor under test;
  - Ex: external DC source;
  - C1: isolation capacitor  $C1 \geq \frac{1}{10\pi F}$ , F is the test frequency, maximum working voltage > Ex;
  - C2: isolation capacitor  $C2 = 1\mu\text{F}$ , maximum working voltage > Ex;
  - V3, V6: IN4007;
  - V1, V2: 47V, 1W;
  - V4, V5: 5.1V, 1W.

Normally, DC bias voltage is used for measurement of capacitor.

Measurement with DC Bias Current

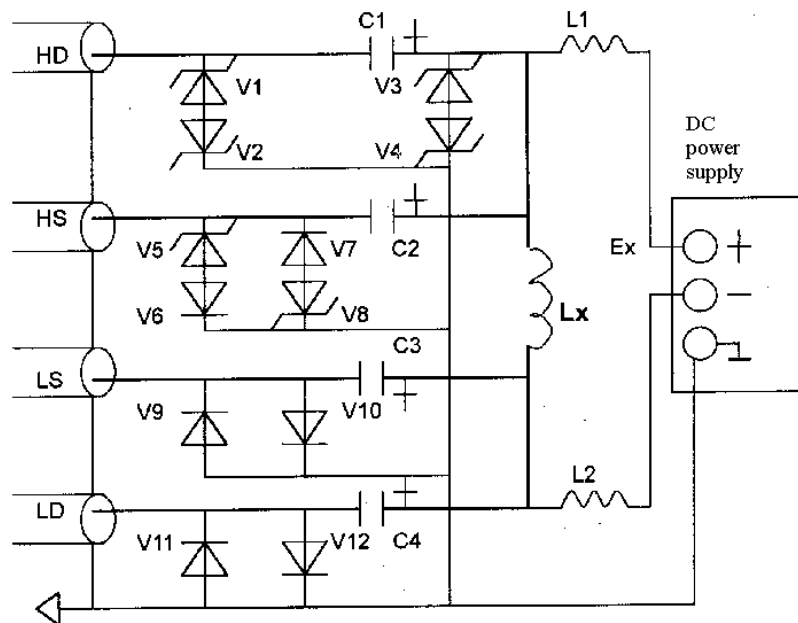

Figure 3-14 Circuit for External DC Bias Current

When TH2817 is applied with external DC bias current, you can adopt TH1771 (0-6A), TH1772 (0-2A) DC bias current sources (DC Bias Current Source) produced by our company. Connect the test cable to the DC Bias Current Source, and connect the component under test to the test terminals of DC Bias Current Source, then inductance and quality factor of the inductor can be measured by TH2817 with DC bias current.

If no DC Bias Current Source is available, the DC bias current can also be applied to the inductor according to Figure 3-14.

In order to eliminate the influence of external circuit, you should make open and short corrections when DC bias current is zero, then you can measure the inductor under the desired DC bias current.

- Where,
- Lx: the inductor under test;
  - Ex: external DC bias source;

C1, C4: isolation capacitor  $C1 \geq \frac{1}{10\pi F}$ , F is the test frequency, and maximum working voltage  $>E_x$ ;  
 C2, C3: isolation capacitor  $C2 = 1\mu F$ , maximum working voltage  $> E_x$ ;  
 V6, V7, V9, V11: IN4007;  
 V1, V2, V3, V4, V5, V7: 47V, 1W;  
 L1, L2:  $L1, L2 \gg L_x$ .

Use an ampere meter in series with the DC source to monitor the actual current, when you adjust the DC voltage to get the desired DC bias current. The ampere meter can be removed after adjustment is finished.

In figure 3-4, HS and LD should be as short as possible. Shielded wire is recommended for each test lead especially for HD and LD.

### 3.4 Troubleshooting

In this paragraph self-test errors are discussed when the instrument is switched on.

If no information is displayed, check the following items:

1. 220V AC power supply;
2. +5V power supply inside the instrument;
3. The reset signal of CPU;
4. The high frequency pulses on the pins 29 and 30 of CPU;
5. The display unit.

Normally, “**TONGHUI TH2817**” is displayed and shifted in the windows of Display

A and Display B, then self-tests are performed. Self-tests are stopped when an error occurs.

Press any key to continue the self-tests.

Note: the test fixture should be opened when the instrument is switched on.

The self-tests are discussed as follows:

1. 99999 SRA

To check if external RAM (D104) can be read and written normally.

2. 88888 EEP

To check if EEPROM (D105) can be read and written normally. Calibration data and correction data are stored in this chip. The instrument should be sent back to our company for maintenance, if there is an error with the EEPROM.

3. Check the calibration data for each measurement range:

77777	r-0	( 100kΩ range or range 0);
77777	r-1	( 10kΩ range or range 1);
77777	r-2	( 1kΩ range or range 2);
77777	r-3	( 100Ω range or range 3);
77777	r-4	( 10Ω range or range 4).

When error occurs, the instrument should be sent back to our company for calibration.

4. 66666 F-0

The frequency calibration data is checked. The instrument should be sent back to our company for maintenance.

5. Check the measurement frequency:

55555 F-0.10

55555 F-1.00

55555 F-10.0

Three frequencies of 100Hz, 1kHz and 10kHz are checked.

D111 (8253) is used to check the frequencies. If frequency can't be generated, then following information will be displayed:

55555 NOF \_\_

If 8253 can't generate UNK signal, then following information will be displayed:

55555 UNK

0.10 means 100Hz;

1.0 means 1kHz;

10.0 means 10kHz.

6. Check the A/D converter:

44444 AD1

44444 AD2

If A/D converter operates normally, the second information would not be displayed. AD2 means that A/D conversion can be finished for a long time.

The failure of A/D converter occurs in many cases. Oscilloscope is often used to check the waves and shapes in the circuit. Your better choice is to send the instrument back to our company for maintenance.

7. 33333 SINE

The magnitude of  $10V_{p-p}$  generated by the signal source is checked.

8. Check the measurement voltage level:

22222 U-0.10

22222 U-0.30

22222 U-1.00

The instrument checks the three voltage levels 0.1V, 0.3V and 1V at the frequency of 1 kHz. When the test levels are checked, make sure that test terminals is opened, otherwise the instrument will not pass the level test.

9. 11111 CUR

The current is checked when nothing is connected to the test terminals, level = 1Vrms, frequency = 1 kHz and range = 2. An error occurs when the current is larger than 10  $\mu$ A.

When all self-tests are passed, this means the instrument works normally. However the measurement accuracy of the instrument is not checked.

## 4 Chapter □ Packing and Warranty

### 4.1 □ Packing

The contents are listed as follows:

Description	Quantity
1) Model TH2817 Precision LCR Meter	1
2) Th26011 Kelvin Test Cables	1
3) Th26005 Test Fixture	1
4) Three-Wire Power Cable	1
5) 1A Fuse	2
6) Operation Manual	1
7) Certificate of Quality	1
8) Test Report	1
9) Warranty Card	1

Check the contents when you received the instrument. If the contents are incomplete, if there is mechanical damage or defect, or if the instrument does not pass the power-on self-tests, please contact our company or business department immediately.

The printer should be purchased by customer himself.

### 4.2 □ Warranty

The period of warranty: the period of warranty will start from the date the instrument is delivered. The period of warranty is two years. The warranty card is needed when the instrument needs to be repaired. The foregoing warranty shall not apply to defects resulting from improper or inadequate maintenance by Buyer.